

IEEE Standard for Separable Insulated Connector Systems for Power Distribution Systems Above 600 V

Sponsor

**Transmission and Distribution Committee
of the
IEEE Power Engineering Society**

Approved March 16, 1995

IEEE Standards Board

Abstract: Definitions, service conditions, ratings, interchangeable construction features, and tests are established for load-break and dead-break separable insulated connector systems rated 601 V and above, 600 A or less, for use on power distribution systems.

Keywords: dead-break connector, elbow connector, load-break connector, power distribution systems, separable conductor, separable insulated connector systems

The Institute of Electrical and Electronics Engineers, Inc.
345 East 47th Street, New York, NY 10017-2394, USA

Copyright © 1995 by the Institute of Electrical and Electronics Engineers, Inc.
All rights reserved. Published 1995. Printed in the United States of America.

ISBN 1-55937-530-2

No part of this publication may be reproduced in any form, in an electronic retrieval system or otherwise, without the prior written permission of the publisher.

IEEE Standards documents are developed within the Technical Committees of the IEEE Societies and the Standards Coordinating Committees of the IEEE Standards Board. Members of the committees serve voluntarily and without compensation. They are not necessarily members of the Institute. The standards developed within IEEE represent a consensus of the broad expertise on the subject within the Institute as well as those activities outside of IEEE that have expressed an interest in participating in the development of the standard.

Use of an IEEE Standard is wholly voluntary. The existence of an IEEE Standard does not imply that there are no other ways to produce, test, measure, purchase, market, or provide other goods and services related to the scope of the IEEE Standard. Furthermore, the viewpoint expressed at the time a standard is approved and issued is subject to change brought about through developments in the state of the art and comments received from users of the standard. Every IEEE Standard is subjected to review at least every five years for revision or reaffirmation. When a document is more than five years old and has not been reaffirmed, it is reasonable to conclude that its contents, although still of some value, do not wholly reflect the present state of the art. Users are cautioned to check to determine that they have the latest edition of any IEEE Standard.

Comments for revision of IEEE Standards are welcome from any interested party, regardless of membership affiliation with IEEE. Suggestions for changes in documents should be in the form of a proposed change of text, together with appropriate supporting comments.

Interpretations: Occasionally questions may arise regarding the meaning of portions of standards as they relate to specific applications. When the need for interpretations is brought to the attention of IEEE, the Institute will initiate action to prepare appropriate responses. Since IEEE Standards represent a consensus of all concerned interests, it is important to ensure that any interpretation has also received the concurrence of a balance of interests. For this reason IEEE and the members of its technical committees are not able to provide an instant response to interpretation requests except in those cases where the matter has previously received formal consideration.

Comments on standards and requests for interpretations should be addressed to:

Secretary, IEEE Standards Board
445 Hoes Lane
P.O. Box 1331
Piscataway, NJ 08855-1331
USA

IEEE Standards documents may involve the use of patented technology. Their approval by the Institute of Electrical and Electronics Engineers does not mean that using such technology for the purpose of conforming to such standards is authorized by the patent owner. It is the obligation of the user of such technology to obtain all necessary permissions.

Introduction

(This introduction is not part of IEEE Std 386-1995, IEEE Standard for Separable Insulated Connector Systems for Power Distribution Systems Above 600 V.)

This standard was developed in response to a need created by the rapid expansion of underground distribution systems. A key element that allowed this expansion to become a reality is the separable insulated conductor. This device provides for simple and inexpensive connection and switching to transformers and other equipment used in underground distribution.

When separable insulated conductors became available, the Institute of Electrical and Electronics Engineers (IEEE) and the National Electrical Manufacturers Association (NEMA) worked cooperatively to develop a document that defined the interfaces, ratings, and test conditions for the device. The success of that cooperative effort is apparent from both the vast number of these devices now in interchangeable use in the field and their enviable safety record.

This cooperative effort continues due to the ongoing upgrading and changing nature of these underground systems and products. The recent cooperative effort has been provided by the ANSI C119.2 Subcommittee and the IEEE Working Group on Separable Connectors under the auspices of the Distribution Subcommittee of the Transmission and Distribution Committee of the IEEE Power Engineering Society.

This revision reflects the following major additions:

- An accelerated current-cycling test for 200 A insulated connectors
- Production test requirements calling for test components to duplicate fit and voltage stress
- Stacking dimension criteria for 200 A separable connectors

At the time this revision of the standard was completed, the ANSI C119.2 Subcommittee on Separable Insulated Connectors had the following membership:

Frank M. Stepniak, Chair

Richard H. Arndt	Harry L. Hayes III	Donald R. Martin
Harvey Bowles	Roland Heinrichs	Matthew C. Mingoia (<i>Alt.</i>)
T. Walker Brown (<i>Alt.</i>)	Milton E. Jeter	J. David Mintz (<i>Alt.</i>)
Thomas C. Champion	W. Lemen	Walter D. Scharer
Kenneth C. Elliott III	Hector Maestri	Duc Trinh
Reinhard Filter	John M. Makal	Sanford D. Yoder

At the time this revision of the standard was completed, the IEEE Working Group on Separable Connectors had the following membership:

Richard H. Arndt, Chair

Andrew Boatwright	Harry L. Hayes III	Ward Peterson
Vince J. Boliver	Roy E. Jazowski	Robert A. Resuali
T. Walker Brown	Tom Kulas	G. E. "Ed" Rogers
Joe F. Buch	Joe A. Lapoint	Frank M. Stepniak
James J. Burke	John M. Makal	Daniel Ward
Ray Capra	J. David Mintz	Edward L. West
Thomas C. Champion	Paul E. Orehek	Matt Williams
Massoud Ghaemi		Sanford D. Yoder

The following persons were on the IEEE Transmission and Distribution balloting committee:

Richard H. Arndt
James J. Burke
L. H. Fink
I. S. Grant
J. G. Kappenman

George Karady
Nestor Kolcio
Keith E. Lindsey
J. H. Mallory
Thomas J. McDermott
Franklin D. Myers

D. L. Nickel
Stig L. Nilsson
Robert G. Oswald
W. Edward Reid
B. R. Shperling

When the IEEE Standards Board approved this standard on March 16, 1995, it had the following membership:

E. G. “Al” Kiener, *Chair*

Donald C. Loughry, *Vice Chair*

Andrew G. Salem, *Secretary*

Gilles A. Baril
Clyde R. Camp
Joseph A. Cannatelli
Stephen L. Diamond
Harold E. Epstein
Donald C. Fleckenstein
Jay Forster*
Donald N. Heirman

Richard J. Holleman
Jim Isaak
Ben C. Johnson
Sonny Kasturi
Lorraine C. Kevra
Ivor N. Knight
Joseph L. Koepfinger*
D. N. “Jim” Logothetis
L. Bruce McClung

Marco W. Migliaro
Mary Lou Padgett
John W. Pope
Arthur K. Reilly
Gary S. Robinson
Ingo Rusch
Chee Kiow Tan
Leonard L. Tripp

*Member Emeritus

Also included are the following nonvoting IEEE Standards Board liaisons:

Satish K. Aggarwal
Richard B. Engelman
Robert E. Hebner
Chester C. Taylor

Valerie E. Zelenty
IEEE Standards Project Editor

Contents

CLAUSE	PAGE
1. Scope.....	1
2. References.....	1
3. Definitions	2
4. Service conditions.....	5
4.1 Usual service conditions	5
4.2 Unusual service conditions	5
5. Ratings and characteristics.....	5
5.1 Voltage ratings.....	5
5.2 Current ratings	6
6. Construction.....	6
6.1 Identification.....	6
6.2 Operating means	7
6.3 Shielding	7
6.4 Interchangeability	7
6.5 Test point	8
6.6 Hold-down bails.....	8
7. Testing	24
7.1 Production tests.....	24
7.2 Design tests.....	24
7.3 Test conditions.....	24
7.4 Corona voltage level	24
7.5 Dielectric tests.....	24
7.6 Short-time current test	26
7.7 Switching test.....	26
7.8 Fault-closure test.....	29
7.9 Current-cycling test for uninsulated components of 600 A connectors.....	29
7.10 Current-cycling test for 200 A insulated connectors	30
7.11 Current-cycling test for 600 A insulated connectors	33
7.12 Accelerated sealing life test	34
7.13 Cable pull-out test (tensile strength).....	35
7.14 Operating-force test	35
7.15 Operating-eye test.....	35
7.16 Test point cap test	35
7.17 Test point tests	36
7.18 Shielding test.....	36

FIGURE

PAGE

1	Typical components of 200 A separable insulated connector system	3
2	Typical components of 600 A separable insulated connector system	4
3	200 A Bushing-well interface, 8.3 kV, 15.2 kV, and 21.1 kV.....	9
4	200 A Dead-break interface, 8.3 kV and 15.2 kV	10
5	200 A Load-break interface, 8.3 kV and 8.3 kV/14.4 kV.....	11
6	200 A Load-break probe and elbow, 8.3 kV and 8.3 kV/14.4 kV	12
7	200 A Load-break interface, 15.2 kV and 15.2 kV/26.3 kV; 200 A load-break interface No. 2, 21.1 kV and 21.1 kV/36.6 kV	13
8	200 A Load-break interface No. 1A, 21.1 kV/36.6 kV	14
9	200 A Load-break interface No. 1B, 21.1 kV.....	15
10	200 A Dead-break interface, 21.1 kV	16
11	600 A Dead-break interface No. 1, 8.3 kV and 15.2 kV	17
12	600 A Dead-break interface No. 2, 8.3 kV and 15.2 kV	18
13	600 A Dead-break interface No. 1, 21.1 kV	19
14	600 A Dead-break interface No. 2, 21.1 kV	20
15	Insulated cap for 200 A load-break interface, 8.3 kV and 15.2 kV	21
16	200 A Separable connector stacking dimensions for tank wall mounting.....	22
17	200 A Separable connector stacking dimensions for insulated parking or grounding bushing and elbow	23
18	200 A Separable connector stacking dimensions for cable junctions.....	23
19	Circuit diagrams for switching current tests	27
20	Circuit diagrams for fault-closure tests.....	30
21	Operating-force test for 7.10.2.....	32

TABLE

1	Voltage ratings and characteristics	5
2	Current ratings and characteristics.....	6
3	Static operating force	7
4	Design tests	25
5	Impulse waveshape tolerances	26
6	Voltage conditions for switching test	28
7	Elbow spacing for switching and fault-closure tests	28
8	Voltage conditions for fault-closure test.....	29
9	Cable insulation thickness for accelerated thermal test	31
10	Cable insulation thickness for thermal off-axis test.....	33
11	Cable insulation thickness for 600 A current cycling test	34

IEEE Standard for Separable Insulated Connector Systems for Power Distribution Systems Above 600 V

1. Scope

This standard establishes definitions, service conditions, ratings, interchangeable construction features, and tests for load-break and dead-break separable insulated connector systems rated 601 V and above, 600 A or less, for use on power distribution systems.

2. References

This standard shall be used in conjunction with the following standards. When the following standards are superseded by an approved revision, the revision shall apply.

ANSI C119.4-1991, Electrical Connectors—Connectors for Use between Aluminum-to-Aluminum or Aluminum-to-Copper Bare Overhead Connectors.¹

IEEE Std 4-1995, IEEE Standard Techniques for High-Voltage Testing.²

IEEE Std 100-1992, The New IEEE Standard Dictionary of Electrical and Electronics Terms (ANSI).³

IEEE Std 592-1990, IEEE Standard for Exposed Semiconducting Shields on High-Voltage Cable Joints and Separable Insulated Connectors (ANSI).

IEEE Std C37.09-1979 (Reaff 1988), IEEE Standard Test Procedure for AC High-Voltage Circuit Breakers Rated on a Symmetrical Current Basis (ANSI).

IEEE Std C62.1-1989 (Reaff 1994), IEEE Standard for Gapped Silicon-Carbide Surge Arresters for AC Power Circuits (ANSI).

NEMA CC4-1986 (R1992), 8.3 kV and 8.3/14.4 kV Probe for Separable Insulated Loadbreak Connectors.⁴

¹ANSI publications are available from the Sales Department, American National Standards Institute, 11 West 42nd Street, 13th Floor, New York, NY 10036, USA.

²As this standard goes to press, IEEE Std 4-1995 is approved but not yet published. The draft standard is, however, available from the IEEE. Anticipated publication date is Fall 1995. Contact the IEEE Standards Department at 1 (908) 562-3800 for status information.

³IEEE publications are available from the Institute of Electrical and Electronics Engineers, 445 Hoes Lane, P.O. Box 1331, Piscataway, NJ 08855-1331, USA.

⁴NEMA publications are available from the National Electrical Manufacturers Association, 2101 L Street NW, Suite 300, Washington, DC 20037, USA.

3. Definitions

The following definitions are the intended meanings of terms used in this standard or associated with separable insulated connector systems. Figures 1 and 2 show typical components of separable insulated connectors. The term *connector* as used in this standard means separable insulated connector.

3.1 bushing insert: A connector component intended for insertion into a bushing well (see figure 1).

3.2 bushing well: An apparatus bushing having a cavity for insertion of a connector component, such as a bushing insert (see figure 1).

3.3 continuous current rating: The designated rms alternating or direct current that the connector can carry continuously under specified conditions.

3.4 dead-break connector: A connector designed to be separated and engaged on de-energized circuits only.

3.5 elbow: A connector component for connecting a power cable to a bushing, so designed that when assembled with the bushing, the axes of the cable and bushing are perpendicular (see figure 1).

3.6 environmental temperature: The temperature of the surrounding medium, such as air, water, or earth, into which the heat of the connector is dissipated directly, including the effect of heat dissipation from associated cables and apparatus.

3.7 fault-closure current rating: The designated rms fault current that a load-break connector can close under specified conditions.

3.8 ground bushing: An accessory device designed to electrically ground and mechanically seal a de-energized power cable terminated with an elbow.

3.9 grounding elbow: An accessory device designed to electrically ground and mechanically seal a bushing insert or an integral bushing.

3.10 hold-down bail: An externally mounted device designed to prevent separation at the operating interface of an elbow and an apparatus bushing.

3.11 insulated cap: An accessory device designed to electrically insulate and shield and mechanically seal a bushing insert or integral bushing.

3.12 insulated parking bushing: An accessory device designed to electrically insulate and shield and mechanically seal a power cable terminated with an elbow.

3.13 integral bushing: An apparatus bushing designed for use with another connector component, such as an elbow (see figures 1 and 2).

3.14 load-break connector: A connector designed to close and interrupt current on energized circuits.

3.15 maximum voltage rating: The highest phase-to-ground or phase-to-ground and phase-to-phase voltage (rms) at which a connector is designed to operate.

3.16 operating interface: The surfaces at which a connector is normally separated (see figures 1 and 2).

3.17 parking stand: A bracket, designed for installation on an apparatus, suitable for holding accessory devices, such as the insulated parking bushing and the grounding bushing.

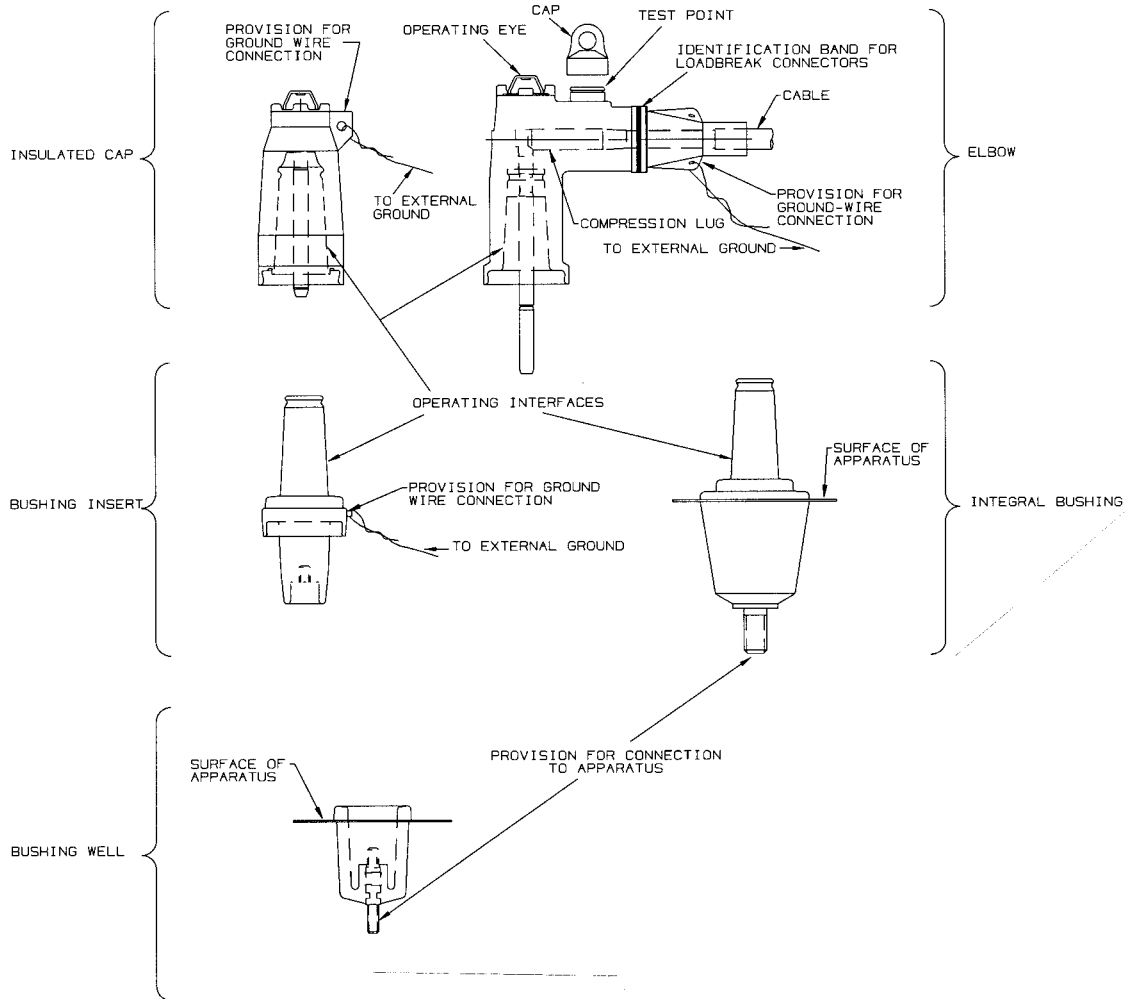

Figure 1—Typical components of 200 A separable insulated connector system

3.18 separable insulated connector: A fully insulated and shielded system for terminating and electrically connecting an insulated power cable to electrical apparatus, other power cables, or both, so designed that the electrical connection can be readily established or broken by engaging or separating the connector at the operating interface (see figures 1 and 2).

3.19 short-time current rating: The designated rms current that a connector can carry for a specified time under specified conditions.

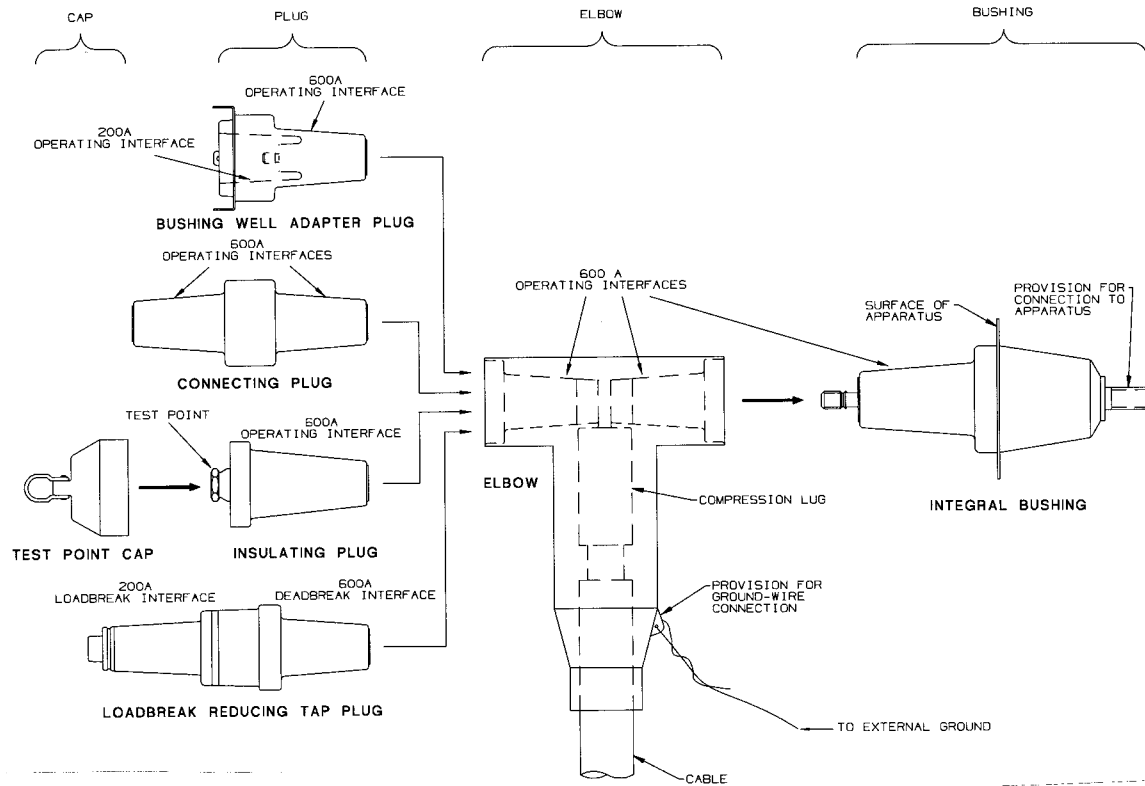

Figure 2—Typical components of 600 A separable insulated connector system

3.20 switching current rating: The designated rms current that a load-break connector can connect and disconnect for a specified number of times under specified conditions.

3.21 test point: A capacitively coupled terminal for use with voltage sensing devices (see figures 1 and 2).

3.22 withstand voltage: The specified voltage that, under specified conditions, can be applied to insulation without causing flashover or puncture.

4. Service conditions

4.1 Usual service conditions

Connectors shall be suitable for use under the following service conditions:

- a) In air, including exposure to direct sunlight
- b) Buried in earth
- c) Intermittently or continuously submerged in water at a depth not exceeding 2 m (6 ft)
- d) Environmental temperatures within the range of $-40\text{ }^{\circ}\text{C}$ to $+65\text{ }^{\circ}\text{C}$ (load-break connectors can be closed and separated within the range of $-20\text{ }^{\circ}\text{C}$ to $+65\text{ }^{\circ}\text{C}$)
- e) Altitudes not exceeding 1800 m (6000 ft) above sea level (applicable to load-break connectors only)

4.2 Unusual service conditions

Conditions other than those listed in 4.1 are considered to be unusual. (The manufacturer should be consulted for recommendations.)

5. Ratings and characteristics

5.1 Voltage ratings

The voltage ratings and characteristics of connectors shall be in accordance with table 1.

Table 1—Voltage ratings and characteristics

Maximum voltage rating (kV rms) ^a	Withstand voltages			
	BIL and full wave (kV crest)	AC 60 Hz for 1 min (kV rms)	DC for 15 min (kV)	Minimum corona (kV rms) ^b
8.3 ^c	95	34	53	11
8.3/14.4 ^d	95	34	53	11
15.2 ^c	125	40	78	19
15.2/26.3 ^d	125	40	78	19
21.1 ^c	150	50	103	26
21.1/36.6 ^d	150	50	103	26

^aThe highest steady-state voltage across the open contacts that a load-break connector is rated to switch is the maximum phase-to-ground rms voltage for phase-to-ground rated devices or the maximum phase-to-phase rms voltage for phase-to-ground/phase-to-phase rated devices.

^bBased on a sensitivity of 3 pC (see 7.4)

^cPhase-to-ground

^dPhase-to-ground/phase-to-phase

5.2 Current ratings

The current ratings and characteristics of connectors shall be in accordance with table 2.

Table 2—Current ratings and characteristics

Continuous current rating (A rms ^a)	Switching current rating (A rms)	Fault-closure current rating ^b			Short-time current rating		
		A rms, symmetrical	Duration (s) ^c	Minimum x/r	A rms, symmetrical	Duration (s)	Minimum x/r
200	200	10 000	0.17	6	10 000	0.17	6
					3500	3.00	6
600	—	—	—	—	25 000	0.17	20
					10 000	3.00	20

^aIn general, the overload capability of a connector exceeds its continuous current rating. Overload capability varies with environment, cable sizes, etc. The connector manufacturer's recommendations should be obtained for the particular combination involved.

^bApplicable to load-break connectors only. Equipment to which these assemblies are affixed may have lower safe limits of current performance.

^cThe manufacturer shall designate the fault-closure duration.

6. Construction

6.1 Identification

Mating components of a separable insulated connector shall be permanently (for example, ink stamped, branded, or molded in) and legibly identified with the following information:

- a) Manufacturer's identification
 - 1) Company name or logo
 - 2) Part identification
 - 3) Date of manufacture
- b) Continuous current rating (when applicable)
- c) Maximum voltage rating
- d) Cable insulation diameter range (when applicable)
- e) Whether load-break or dead-break (when applicable). In addition, elbows of load-break connectors shall have the following marking:
 - 1) Connectors with a phase-to-ground voltage rating shall be identified with a removable white band 13–32 mm (0.5–1.25 in) wide, located on the cable entrance portion of the connector not less than 25 mm (1.00 in) from the cable entrance. The removable band shall be clearly visible from the normal operating position, and affixed to minimize its accidental dislodgment.
 - 2) Connectors with both phase-to-ground and phase-to-phase voltage ratings shall be identified with a removable white band 13–32 mm (0.5–1.25 in) wide, having a centered black stripe 4.8 mm ± 1.6 mm (0.188 in ± 0.062 in) in width located on the cable entrance portion of the connector not less than 25 mm (1.00 in) from the cable entrance. The removable band shall be

clearly visible from the normal operating position, and affixed to minimize its accidental dislodgment.

6.2 Operating means

Connectors shall be operable by means of a suitable live-line tool that clamps the elbow so that operation is along the probe axis. The required operating force over the environmental range of $-20\text{ }^{\circ}\text{C}$ to $+65\text{ }^{\circ}\text{C}$ shall be as follows (see 7.14):

- a) 222–890 N (50–200 lbf) for connectors without hold-down bails
- b) 44–890 N (10–200 lbf) for connectors with hold-down bails

If an operating eye is provided, it shall support a 14 N·m (120 lbf-in) rotational force and shall support a static operating force as shown in table 3.

Table 3—Static operating force

Connector type	Force	
	N	lbf
Dead-break elbow	1334	300
Load-break elbow	2224	500
Grounding elbow	1779	400
Insulated cap	2224	500

6.3 Shielding

Connectors shall have an electrically conductive shield and, where required, shall have provision for connecting an external ground to the shield. Except for nonelastomeric components, connectors shall meet the requirements of IEEE Std 592-1990.⁵

6.4 Interchangeability

6.4.1 Complete interchangeability

Intermixed bushings and elbows of different manufacture shall be considered interchangeable provided that they meet all of the applicable requirements of this standard.

6.4.2 Limited interchangeability

Intermixed bushings and elbows of different manufacture meeting all of the requirements of this standard, except for those in 7.7 and 7.8, shall be considered interchangeable, except for switching and fault closure.

⁵Information on references can be found in clause 2.

6.4.3 Interface dimensions

The dimensions of operating and bushing well interfaces shall be in accordance with figures 3 through 15.

6.4.4 Stacking dimensions

Upon request, each manufacturer shall supply the dimensions in figures 16 through 18 to enable users to determine the dimensional effect of stacking components.

6.5 Test point

Test points are optional and may be specified on either load-break or dead-break elbows.

6.5.1 Capacitance

Test points shall be capacitively coupled to the conductor system and shield of the connector.

The capacitance between the test point and the conductor system shall be at least 1.0 pF. The ratio of the capacitance between test point and shield to the capacitance between test point and conductor system shall not exceed 12.0. These values shall be verified by tests when conducted in accordance with 7.17.1.

6.5.2 Cap removal force

The force required to remove the test point cap shall be within the range of 36–218 N (8–49 lbf). The cap operating eye shall be capable of withstanding a static operating force of 445 N (100 lbf) over the environmental temperature range of –20 °C to +65 °C (see 7.16.1).

6.6 Hold-down bails

Dimensions, materials, and performance criteria are not specified in this standard.

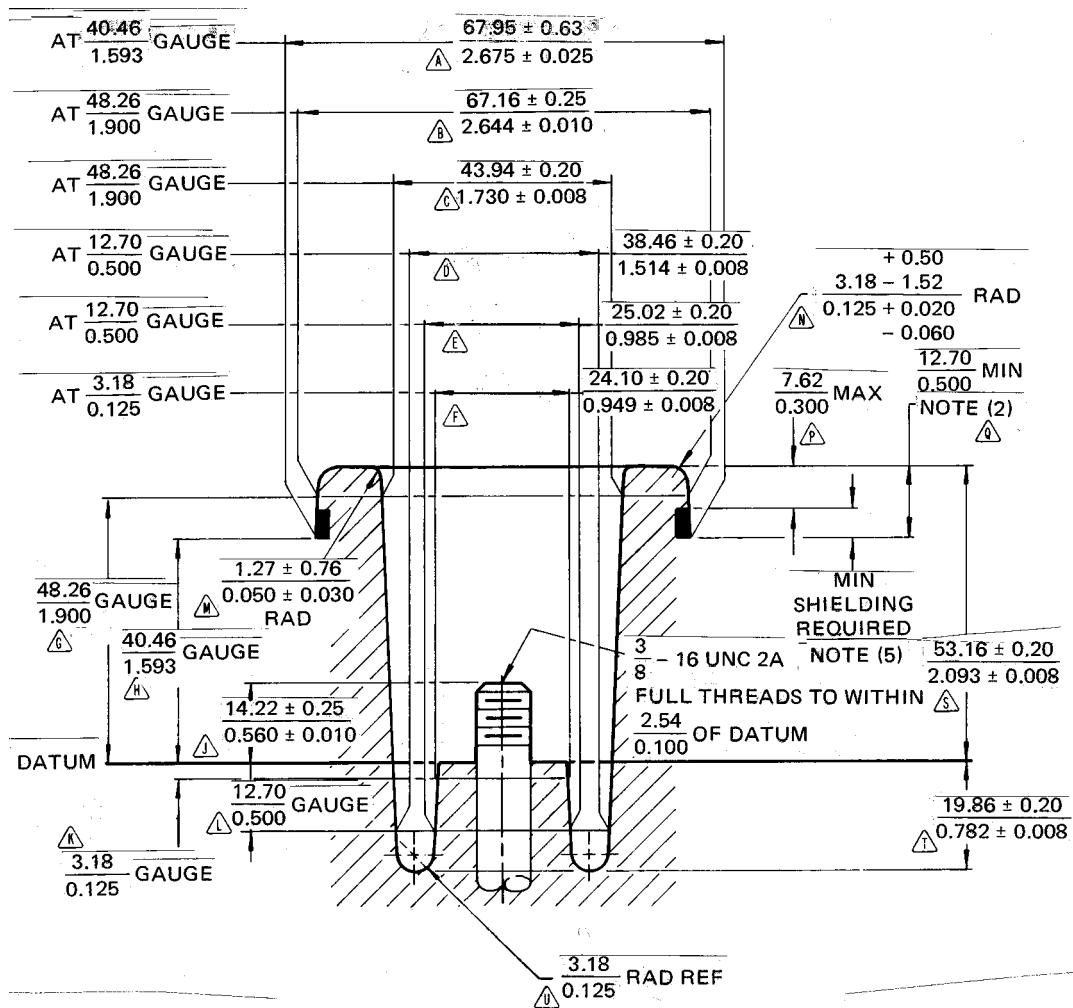

NOTES

- 1—Diameters C, D, E, and F to be concentric with pitch diameter of threads on stud within 0.25/0.010 TIR (total indicator reading)
- 2—Clearance for mating parts
- 3—Dimensions: mm/in; $\frac{\text{mm}}{\text{in}}$
- 4—y – Alphabetical dimensional identification
- 5—The diameter of the shielded portion shall at no point be less than the largest diameter of the insulated portion.

Figure 3—200 A Bushing-well interface, 8.3 kV, 15.2 kV, and 21.1 kV

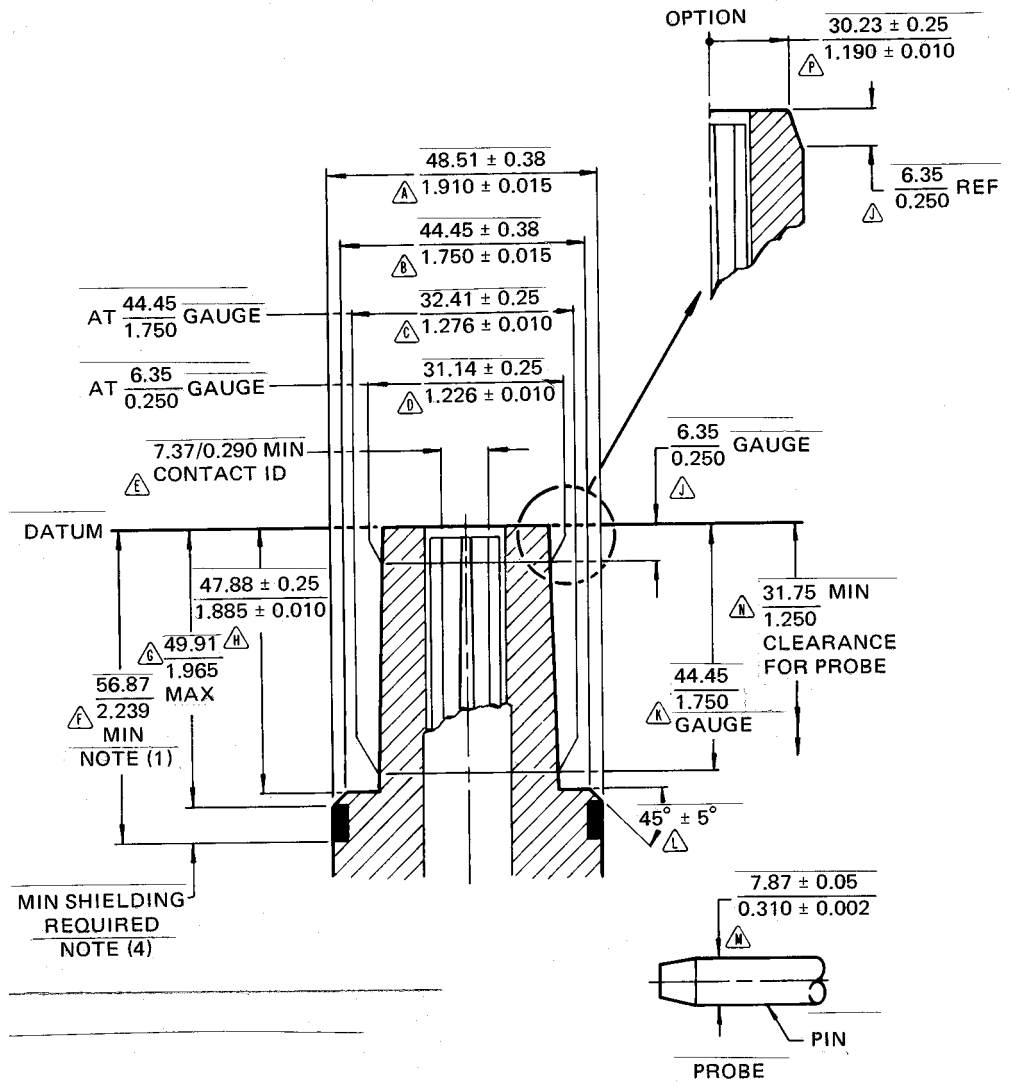

NOTES

- 1—Clearance for mating parts
- 2—Dimensions: mm/in; $\frac{mm}{in}$
- 3—y — Alphabetical dimensional identification
- 4—The diameter of the shielded portion shall at no point be less than the largest diameter of the insulated portion.

Figure 4—200 A Dead-break interface, 8.3 kV and 15.2 kV

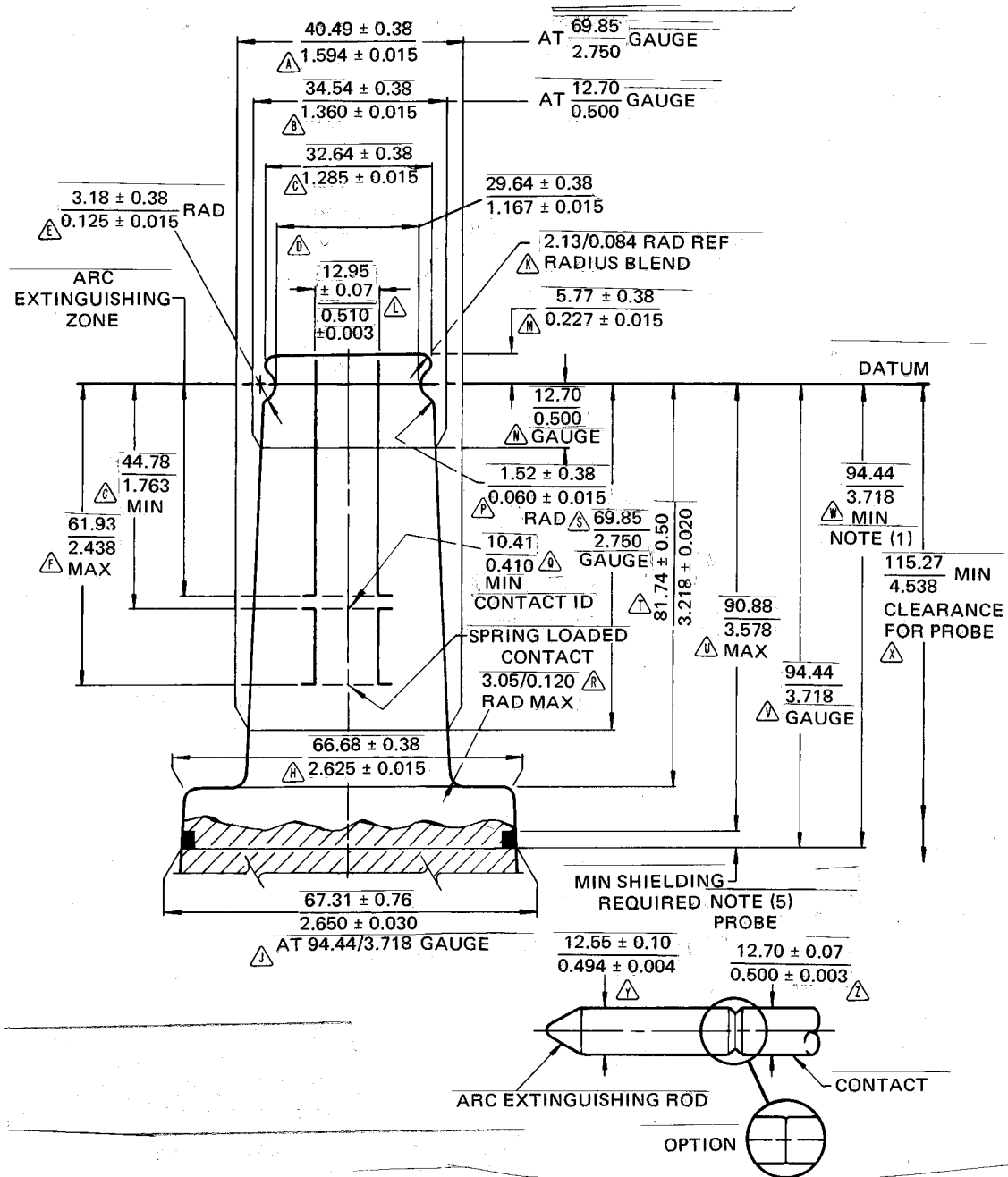
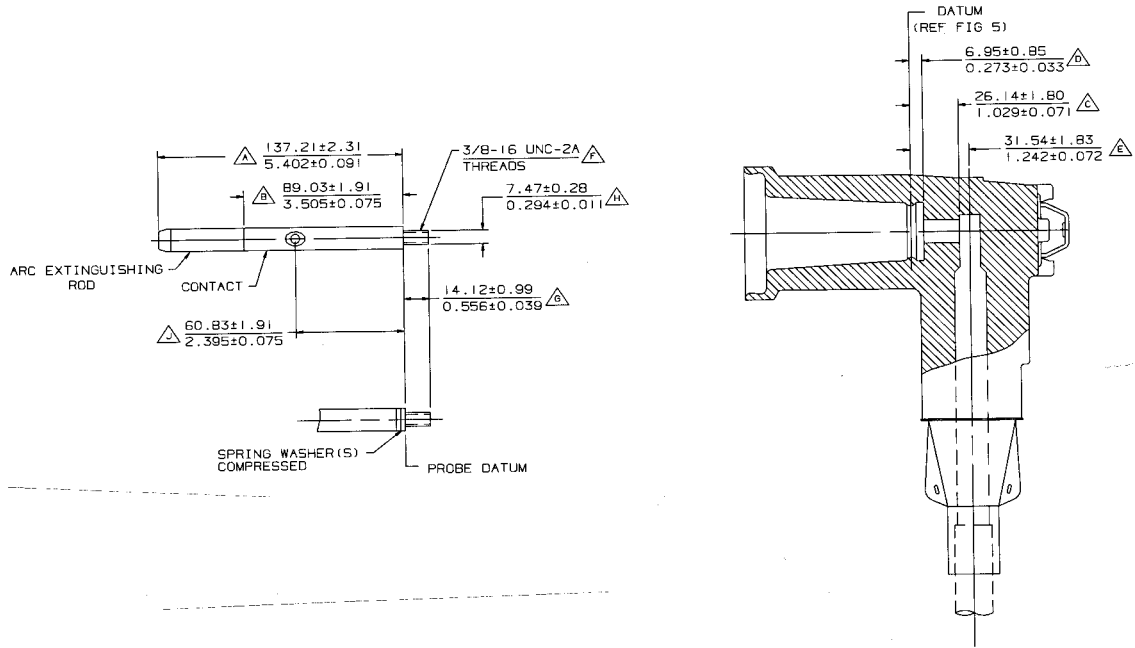

Figure 5—200 A Load-break interface, 8.3 kV and 8.3 kV/14.4 kV



NOTES

- 1—For bushing, see figure 5.
- 2—Dimensions: mm/in; $\frac{mm}{in}$
- 3— γ – Alphabetical dimensional identification

Figure 6—200 A Load-break probe and elbow, 8.3 kV and 8.3 kV/14.4 kV

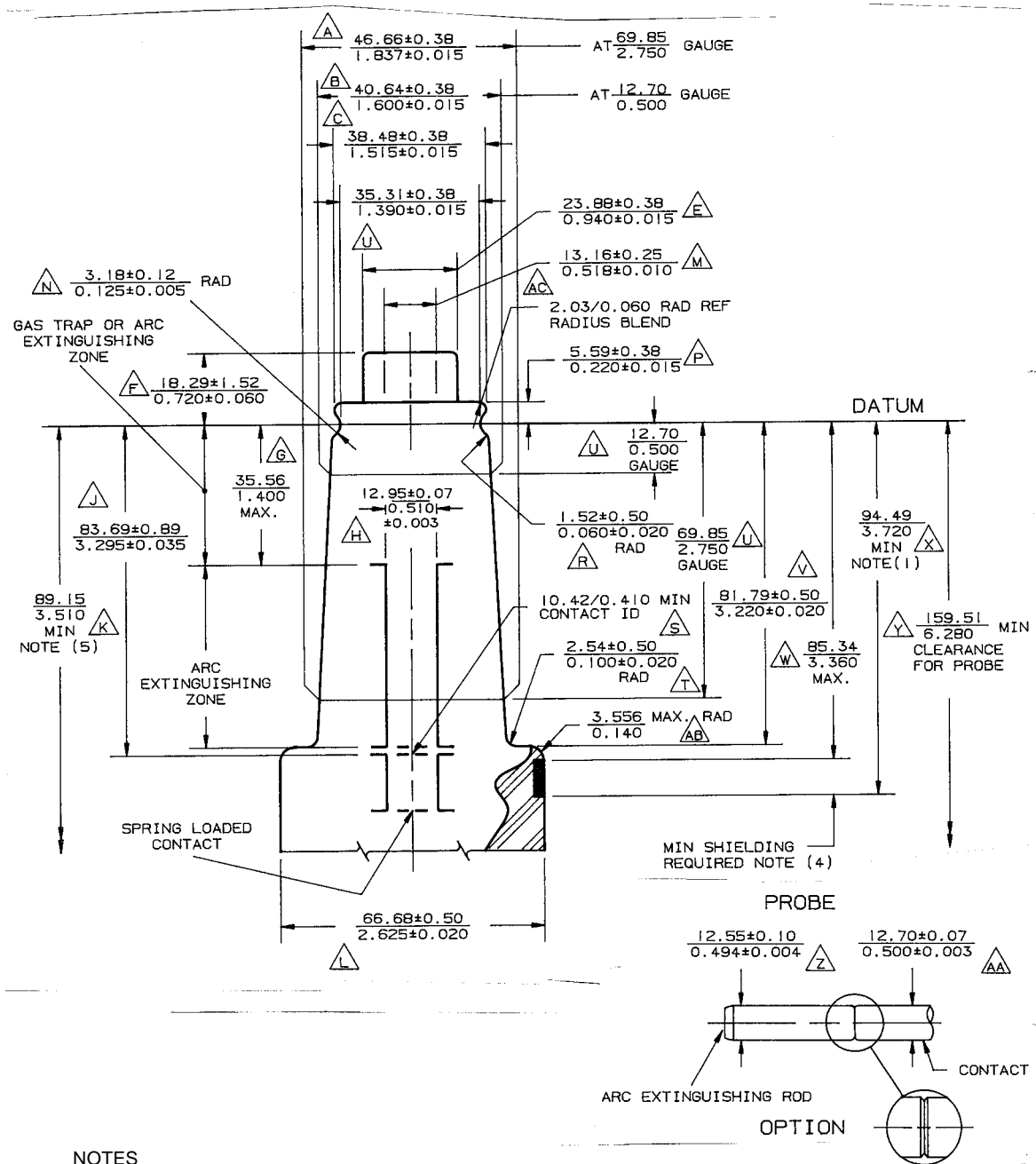

- NOTES
- 1—Clearance for mating parts
 - 2—Dimensions mm/in; $\frac{mm}{in}$
 - 3— \dot{y} – Alphabetical dimensional identification
 - 4—The diameter of the shielded portion shall at no point be less than the largest diameter of the insulated portion.
 - 5—Minimum overlap for mating parts

Figure 7—200 A Load-break interface, 15.2 kV and 15.2 kV/26.3 kV;
200 A load-break interface No. 2, 21.1 kV and 21.1 kV/36.6 kV

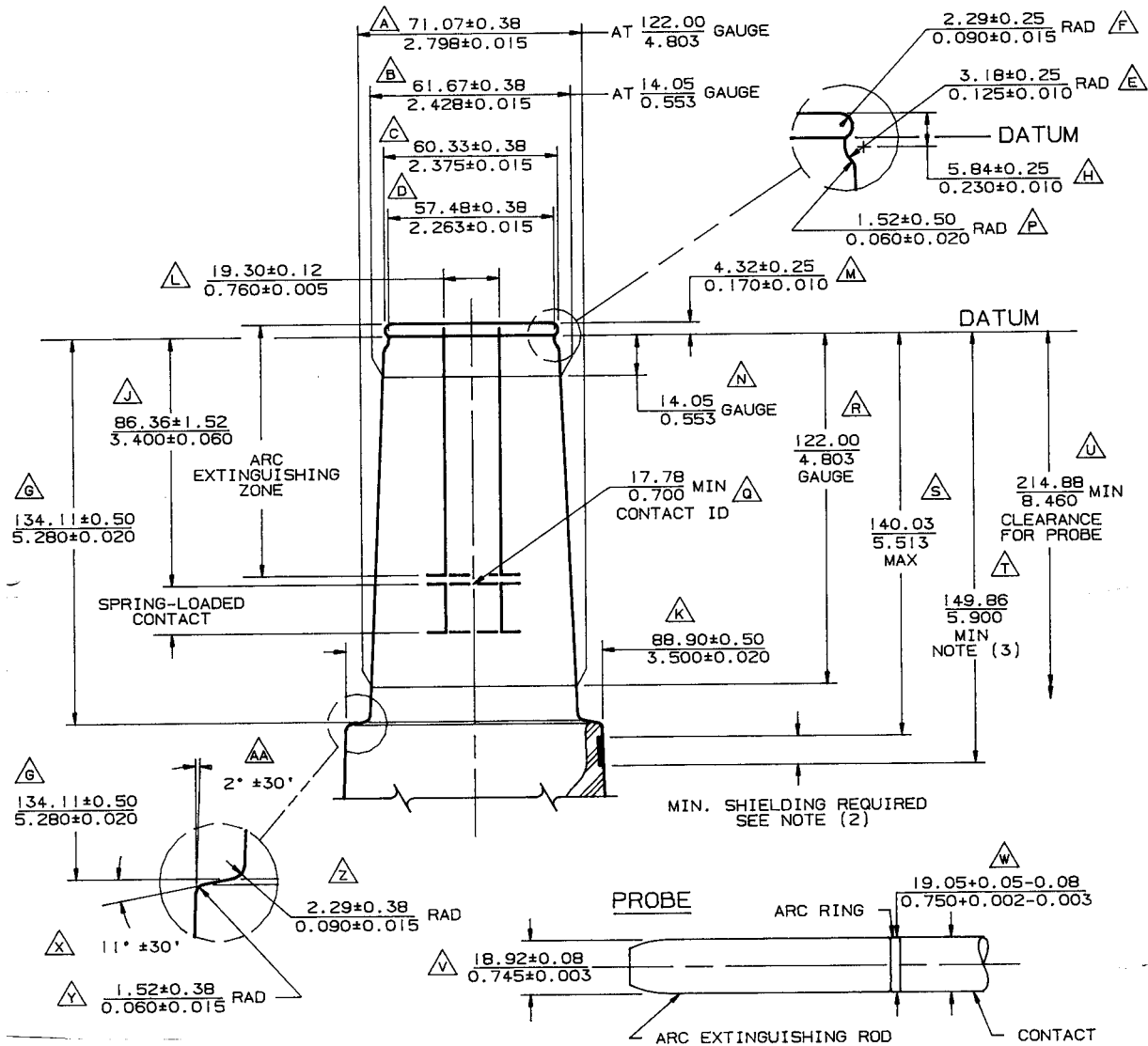

NOTES

- 1—Dimensions mm/in; $\frac{\text{mm}}{\text{in}}$
- 2—The diameter of the shielded portion shall at no point be less than the largest diameter of the insulated portion.
- 3—Minimum overlap for mating parts

Figure 8—200 A Load-break interface No. 1A, 21.1 kV/36.6 kV

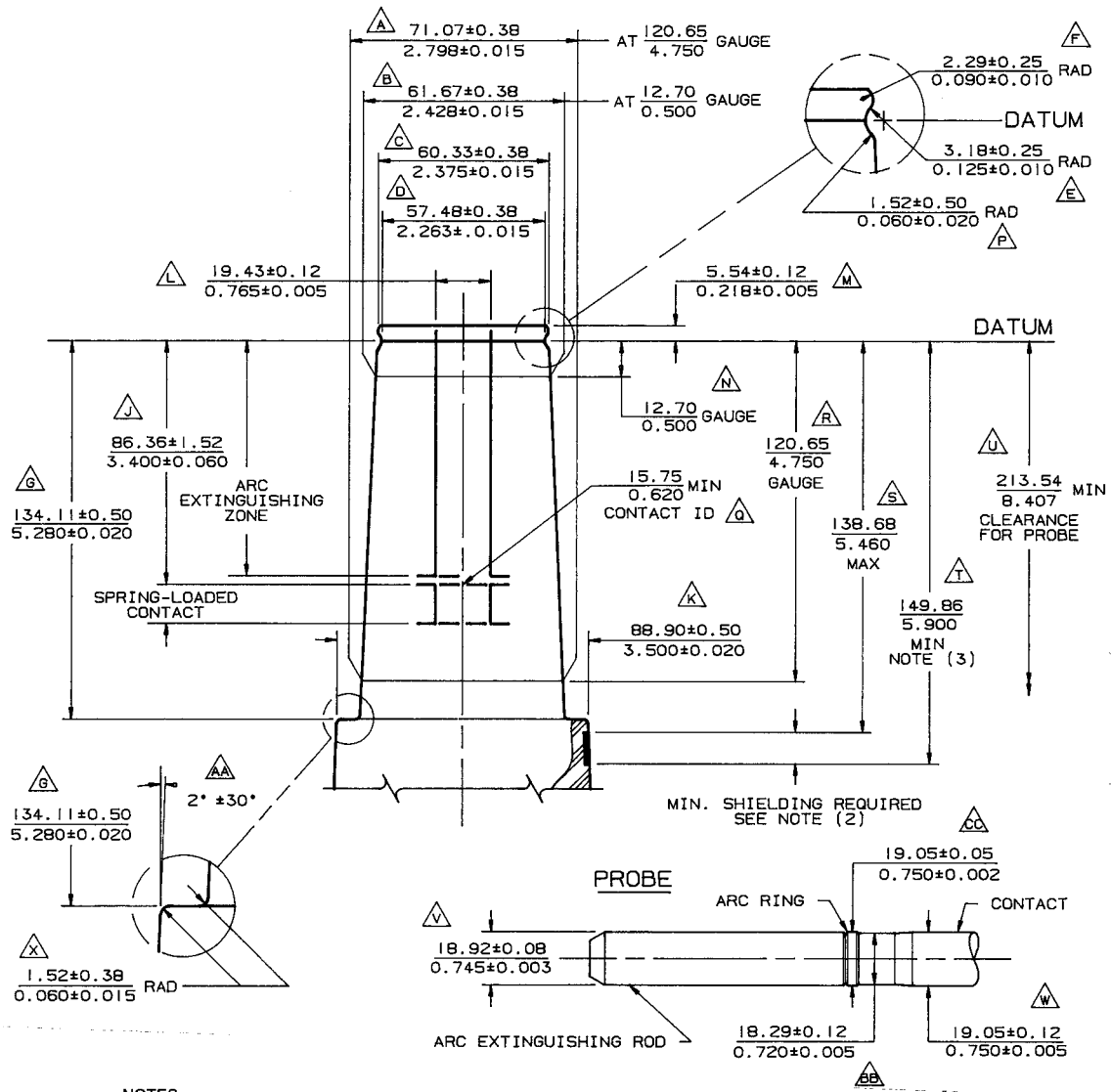
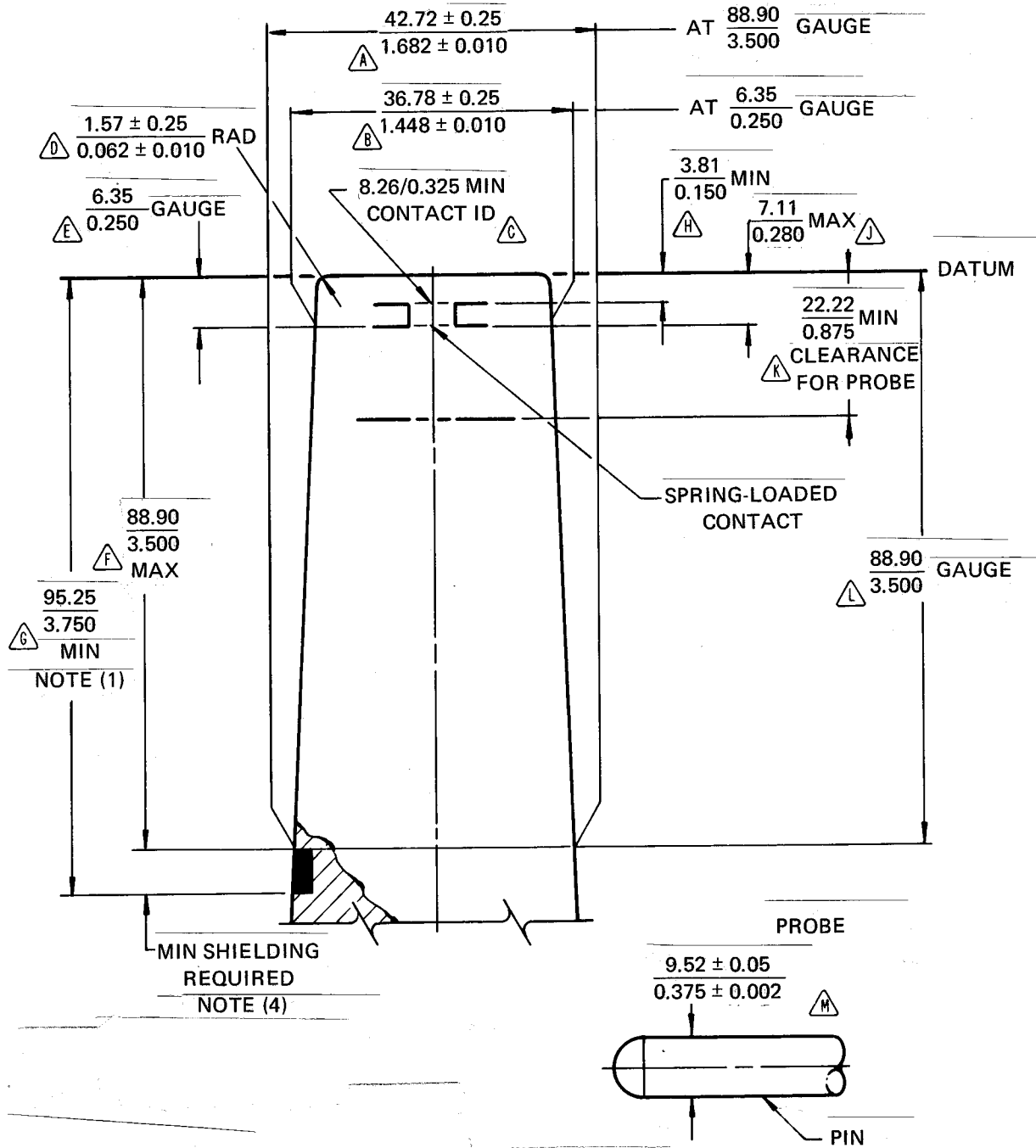
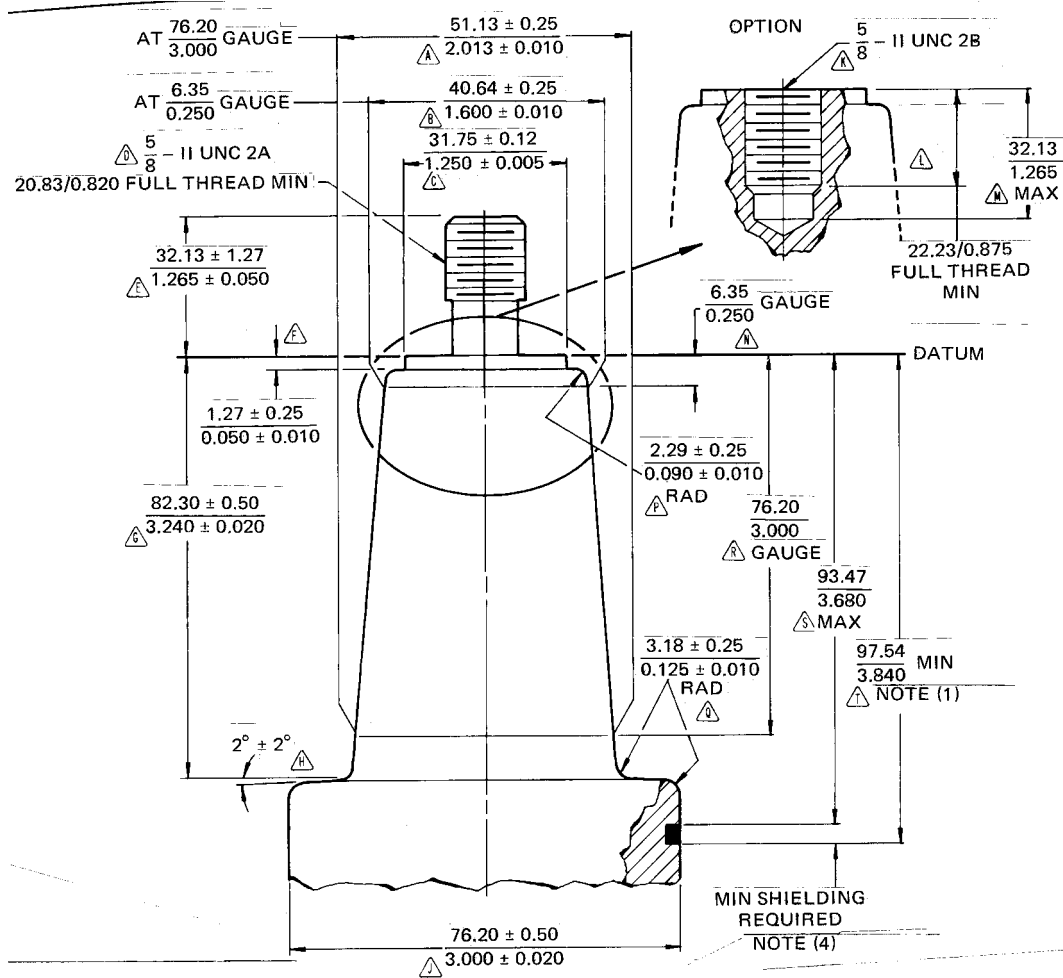

Figure 9—200 A Load-break interface No. 1B, 21.1 kV



- NOTES
- 1—Clearance for mating parts
 - 2—Dimensions mm/in; $\frac{mm}{in}$
 - 3—y – Alphabetical dimensional identification
 - 4—The diameter of the shielded portion shall at no point be less than the largest diameter of the insulated portion.

Figure 10—200 A Dead-break interface, 21.1 kV



NOTES

- 1—Clearance for mating parts
- 2—Dimensions mm/in; $\frac{mm}{in}$
- 3—y – Alphabetical dimensional identification
- 4—The diameter of the shielded portion shall at no point be less than the largest diameter of the insulated portion except for bushings that have internal shielding.

Figure 11—600 A Dead-break interface No. 1, 8.3 kV and 15.2 kV

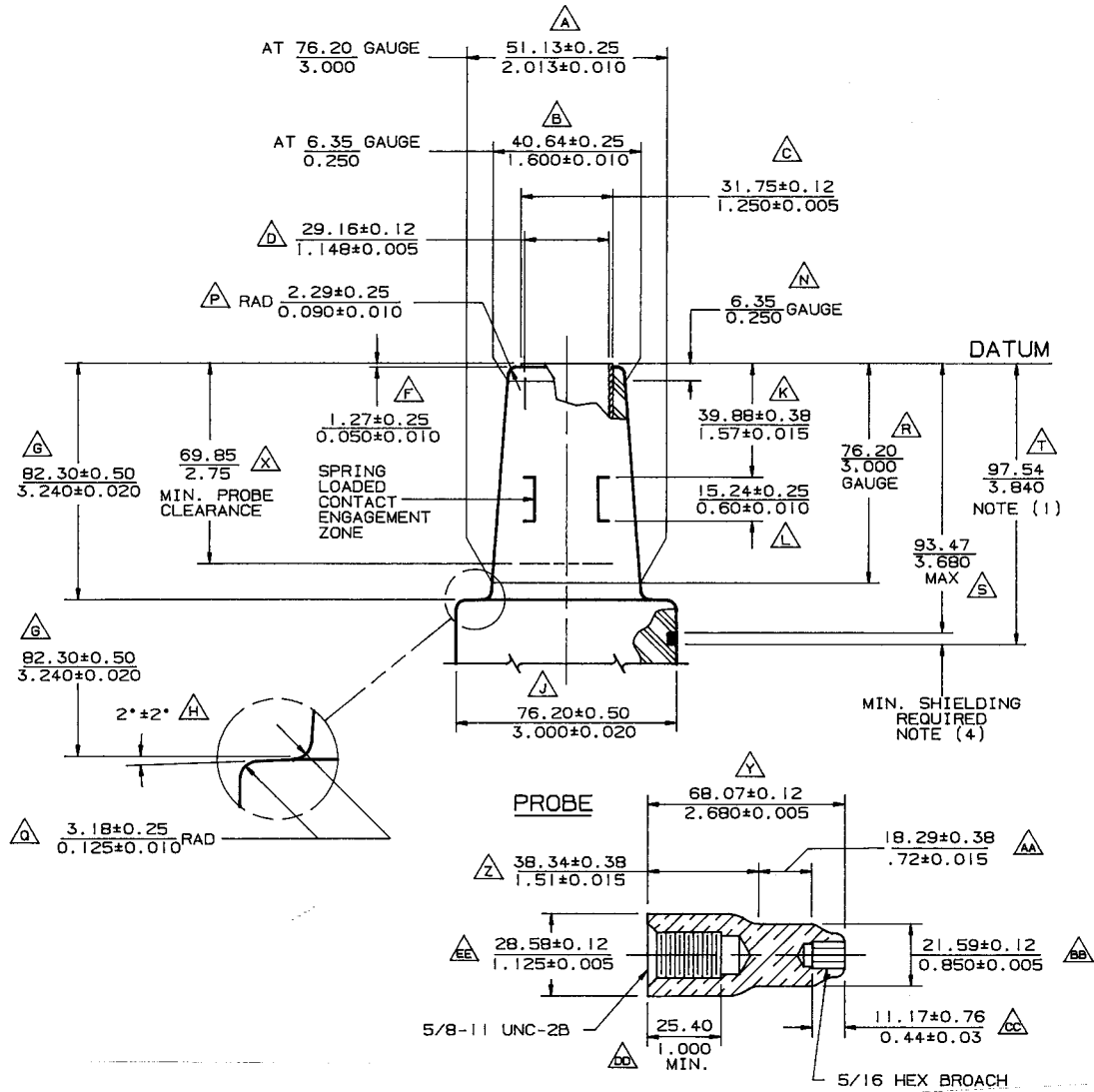

NOTES

- 1—Clearance for mating parts
- 2—Dimensions mm/in; $\frac{mm}{in}$
- 3— \dot{y} – Alphabetical dimensional identification
- 4—The diameter of the shielded portion shall at no point be less than the largest diameter of the insulated portion except for bushings that have internal shielding.
- 5—Operating bracket must be consistent with datum.

Figure 12—600 A Dead-break interface No. 2, 8.3 kV and 15.2 kV

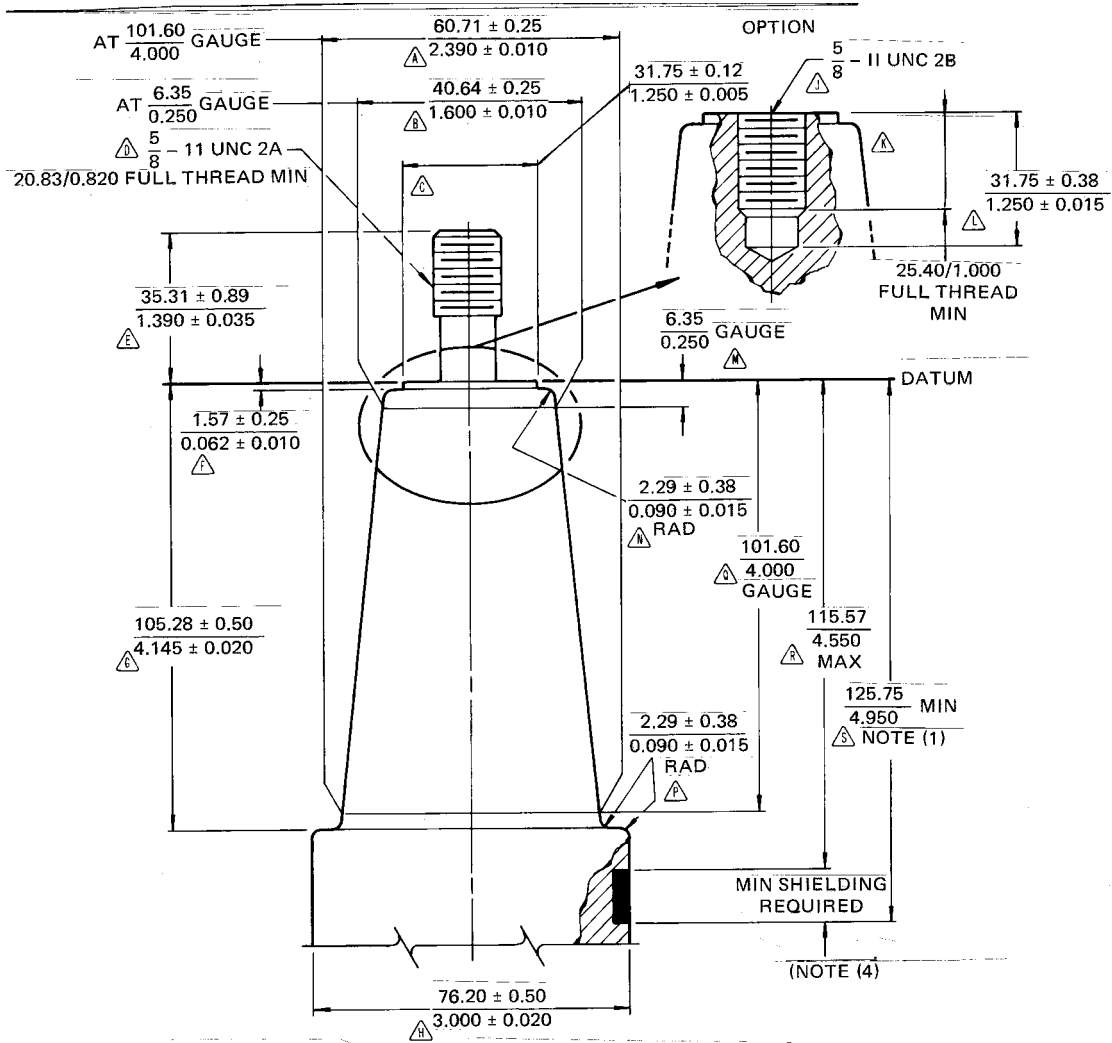

NOTES

1—Clearance for mating parts

2—Dimensions mm/in; $\frac{mm}{in}$

3— \dot{y} – Alphabetical dimensional identification

4—The diameter of the shielded portion shall at no point be less than the largest diameter of the insulated portion except for bushings that have internal shielding.

Figure 13—600 A Dead-break interface No. 1, 21.1 kV

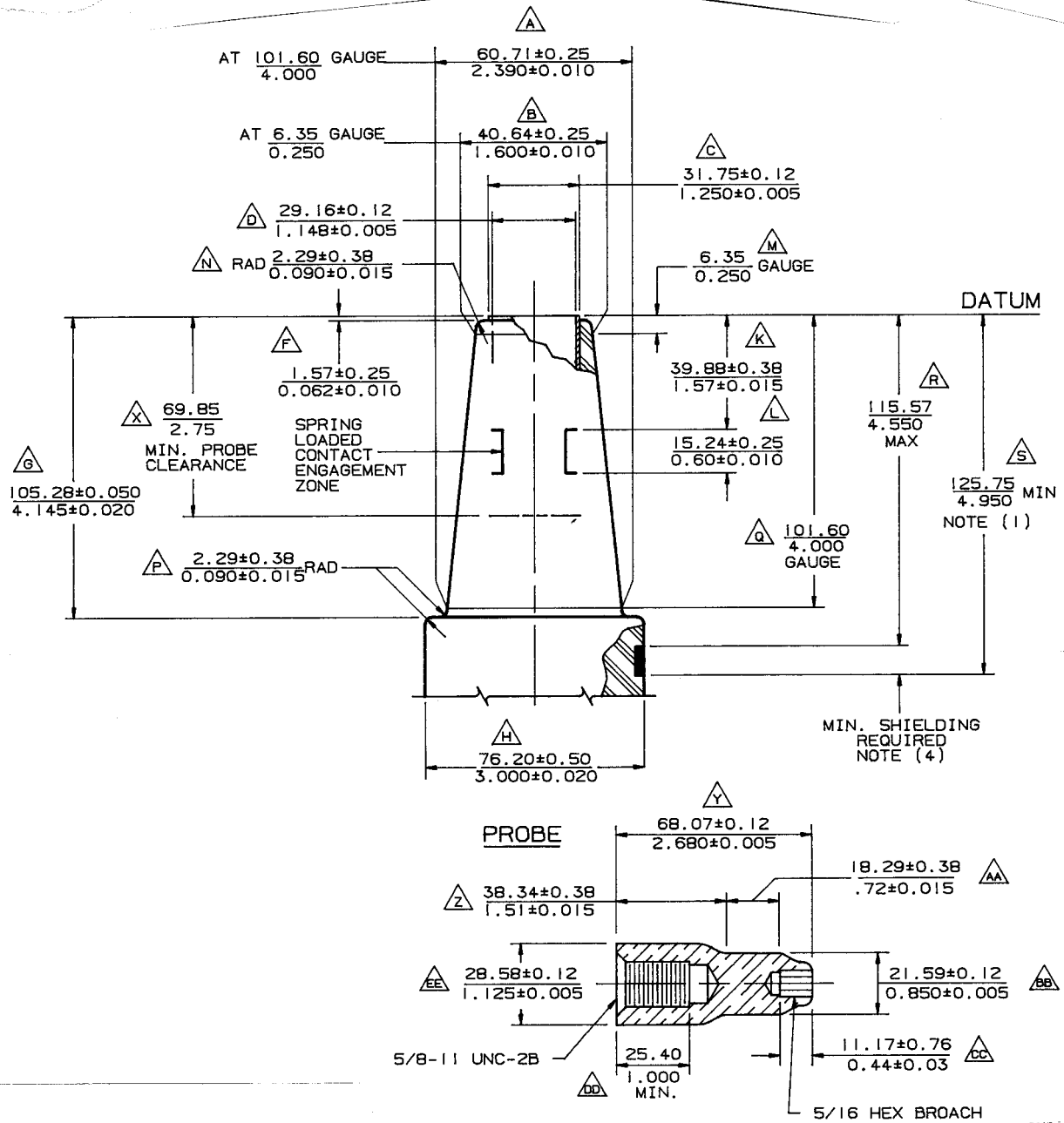

NOTES

- 1—Clearance for mating parts
- 2—Dimensions mm/in; $\frac{mm}{in}$
- 3— \dot{y} – Alphabetical dimensional identification
- 4—The diameter of the shielded portion shall at no point be less than the largest diameter of the insulated portion except for bushings that have internal shielding.
- 5—Operating bracket must be consistent with datum.

Figure 14—600 A Dead-break interface No. 2, 21.1 kV

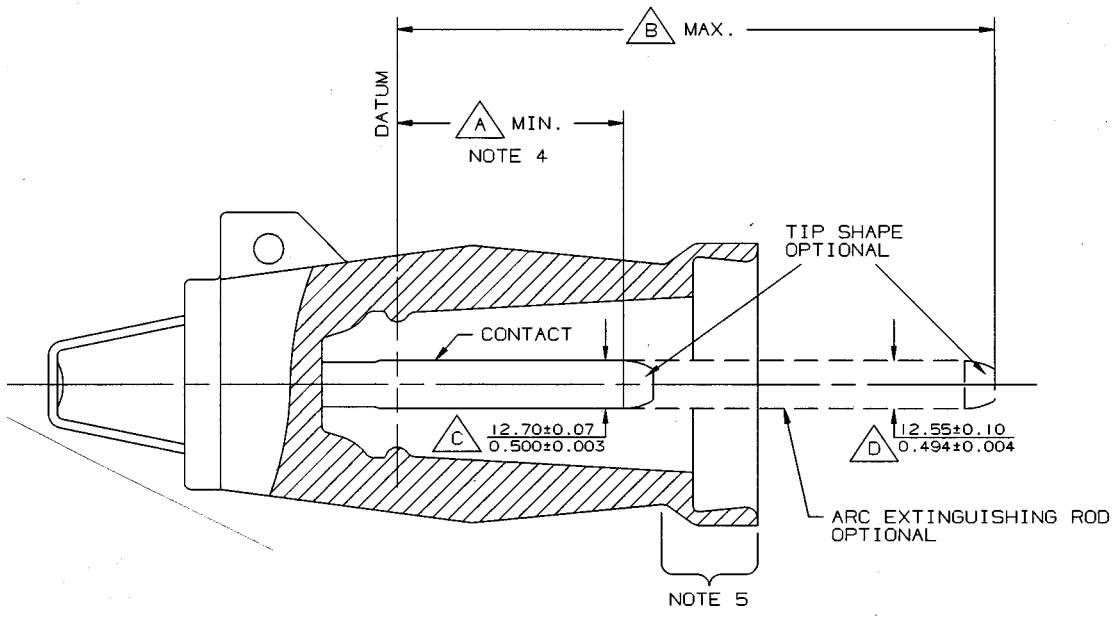

RATING	A (MIN.)	B (MAX.)
8.3kV	$\frac{59.69}{2.35}$	$\frac{113.28}{4.46}$
15.2kV	$\frac{97.03}{3.82}$	$\frac{157.48}{6.20}$

NOTES

- 1—For bushings, see figures 5 and 7.
- 2—Dimensions: $\frac{\text{mm}}{\text{in}}$
- 3—y – Alphabetical dimension identification
- 4—Dimension A is the minimum length of 0.500 ± 0.003 in (12.70 ± 0.007 mm) diameter contact.
- 5—Conductive or nonconductive cuff optional.

Figure 15—Insulated cap for 200 A load-break interface, 8.3 kV and 15.2 kV

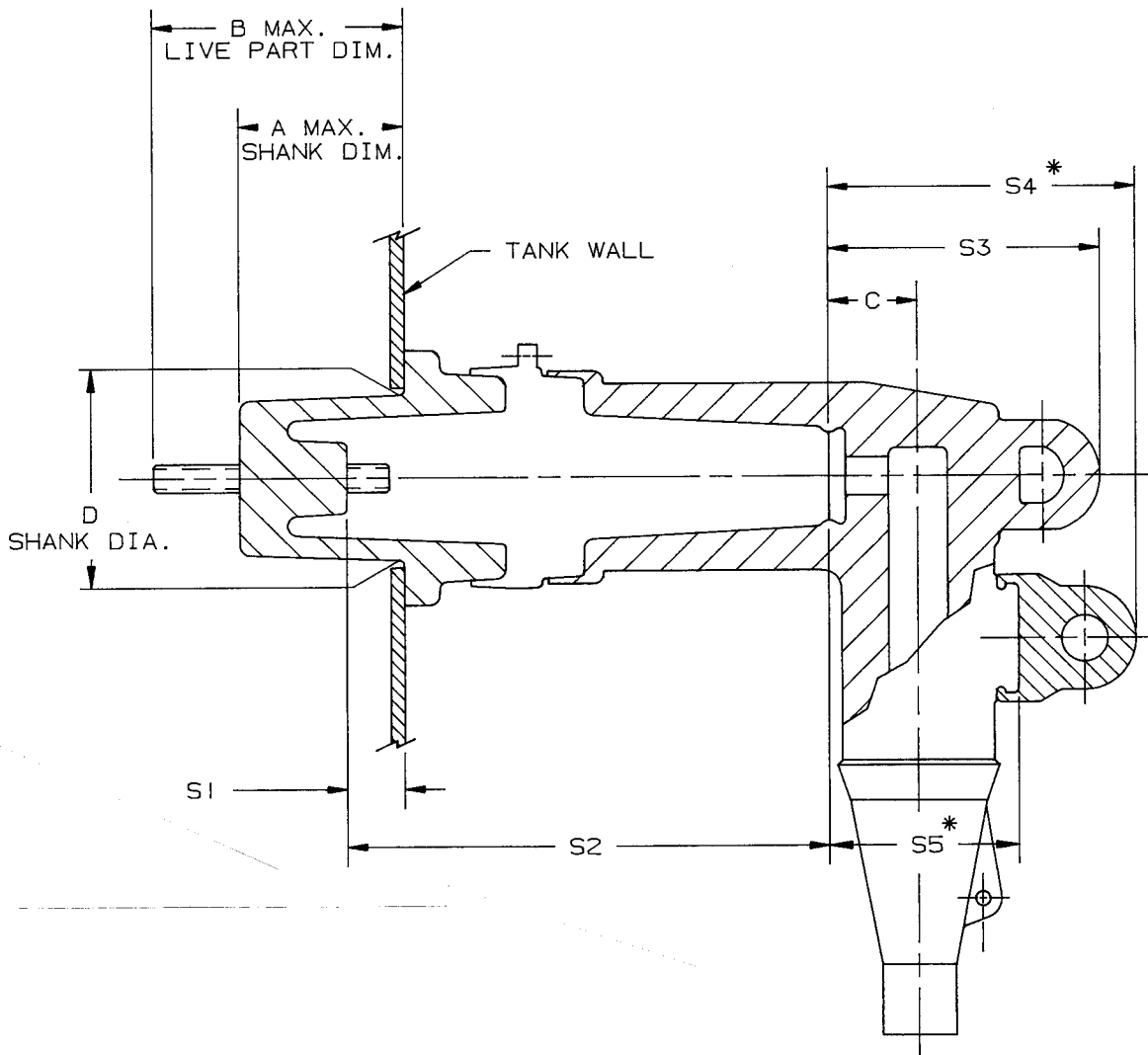

*If test point is provided

NOTE—See 6.4.3.

Figure 16—200 A Separable connector stacking dimensions for tank wall mounting

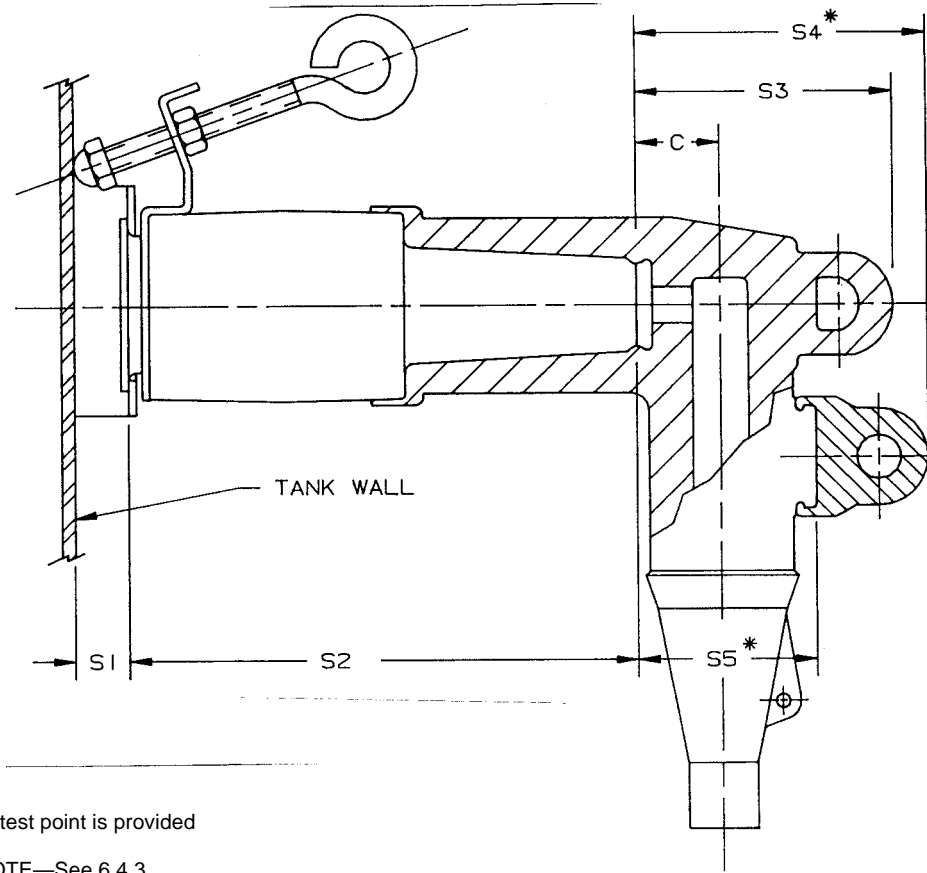

*If test point is provided

NOTE—See 6.4.3.

Figure 17—200 A Separable connector stacking dimensions for insulated parking or grounding bushing and elbow

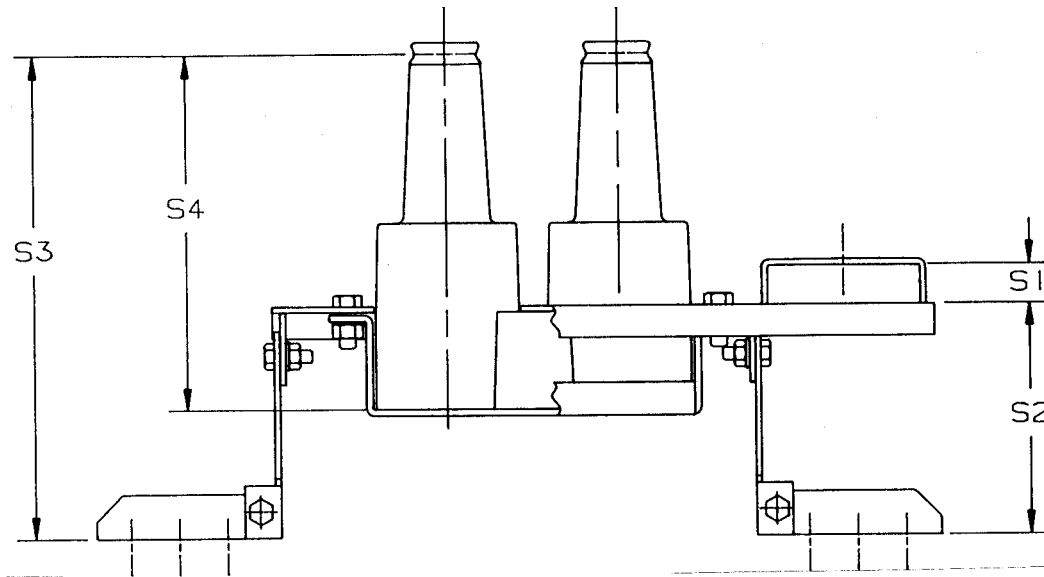

NOTE—See 6.4.3.

Figure 18—200 A Separable connector stacking dimensions for cable junctions

7. Testing

7.1 Production tests

The following production tests shall be performed by the manufacturer on all connector components except ground bushings and grounding elbows:

- a) Corona voltage level (see 7.4)
- b) AC withstand or full-wave impulse withstand voltage (see 7.5.1 and 7.5.3)
- c) Test point voltage test, if applicable (see 7.17.2)

Connectors shall be properly assembled with actual or simulated components that duplicate the fit and voltage stress distribution of the actual components.

7.2 Design tests

The design tests listed in table 4 shall be performed by the manufacturer to demonstrate compliance of the design with this standard. Design tests shall be performed using actual connector system components assembled according to the manufacturer's instructions and using those materials supplied in the manufacturer's packaging.

7.3 Test conditions

The following test conditions shall apply unless otherwise specified:

- a) All parts that are normally grounded shall be connected to the ground of the test circuit.
- b) Ambient temperature shall be in the range of 0 °C to + 40 °C.
- c) All ac voltages shall have a frequency of 60 Hz \pm 5% and sine waveshape of acceptable commercial standards as defined in IEEE Std 4-1995.
- d) Voltages shall be measured in accordance with IEEE Std 4-1995.

7.4 Corona voltage level

The purpose of this test is to verify that the corona voltage level of the test specimen is not less than the value given in table 1.

The test voltage shall be raised to 20% above the corona voltage level specified in table 1. If the corona exceeds 3 pC, the test voltage shall be lowered to the corona voltage level specified in table 1 and shall be maintained at this level for at least 3 s but not more than 60 s. Corona readings taken during this period shall not exceed 3 pC.

7.5 Dielectric tests

The purpose of these tests is to verify that the insulation of the test specimen will withstand the voltages shown in table 1.

The test voltage shall be applied to the parts of the connector that are energized in service.

The test point, if any, shall be grounded during these tests.

7.5.1 AC withstand voltage test

The test voltage shall be raised to the value specified in table 1 in not more than 30 s. The connector shall withstand the specified test voltage for 1 min without flashover or puncture.

Table 4—Design tests

Design test	Reference	Number of samples ^a
Corona voltage level	7.4	10
AC withstand voltage	7.5.1	10
DC withstand voltage	7.5.2	10
Impulse withstand voltage	7.5.3	10
Short-time current	7.6	4
Switching	7.7	30 (max)
Fault-closure	7.8	
Current cycling	7.9–7.11	4
Accelerated sealing life test	7.12	4
Cable pull-out (tensile strength)	7.13	4
Operating force	7.14	4
Operating eye	7.15	4
Test point cap	7.16	4
Test point	7.17	10
Shielding	7.18	4

^aNo failures are permitted except for switching and fault-closure tests in which none are permitted in 10 consecutive samples of a maximum lot size of 30.

7.5.2 DC withstand voltage test

The test voltage shall have a negative polarity (i.e., the negative terminal is connected to the test specimen) and shall be raised to the value specified in table 1. The connector shall withstand the specified test voltage for 15 min without flashover or puncture.

7.5.3 Impulse withstand voltage test (BIL)

The test voltage shall be 1.2/50 μ s wave having the crest value (BIL) specified in table 1. The waveshape shall meet the requirements of IEEE Std C62.1-1989. The waveshape tolerance shall be as shown in table 5.

Table 5—Impulse waveshape tolerances

Measured quantity	Tolerance (%)
Crest value	± 3
Front time	± 30
Time to half value	± 20
Nominal rate of rise of wave front	± 20

The closed connector shall withstand three positive and three negative full-wave impulses without flashover or puncture. When the impulse withstand test is used as a production test, the connector shall withstand one full-wave impulse of each polarity.

7.6 Short-time current test

The purpose of this test is to verify that the connector is capable of withstanding short-time current of the magnitudes and durations shown in table 2.

The connector shall be mounted in a manner approximating service conditions. Hold-down bails shall be used with 200 A dead-break elbows.

Short-time current tests may be made at any voltage up to the rated voltage of the connector.

The rms value of the first major loop of a current wave shall be not less than the value specified in table 2 multiplied by 1.3 (X/R=6) for 200 A connectors or 1.6 (X/R=20) for 600 A connectors. The magnitude shall be measured in accordance with IEEE Std C37.09-1979.

Connectors shall withstand the current without separation of interfaces or impairing the ability to meet the other requirements of the standard.

7.7 Switching test

This test is applicable to load-break connectors only. The purpose of this test is to verify that the load-break connector is capable of closing and interrupting the rated switching current given in table 2.

The connector shall withstand ten complete switching operations under the conditions listed in figure 19 and table 6 without arcing to ground or impairing its ability to meet the other requirements of this standard. A complete switching operation shall consist of connecting and disconnecting. Appropriate ground-fault detection equipment shall be used for all tests. The last switching operation shall be recorded by an oscillogram.

7.7.1 Mounting preparation of load-break connectors for switching tests

The connector shall be mounted with all normally grounded parts grounded in a manner closely approximating normal service conditions. Adjacent grounds, in the form of connector systems of the same type as the one being tested, shall be mounted and appropriately grounded on each side of the connector under test at the distance shown in table 7. If hold-down bails are used, these shall be installed as in normal service.

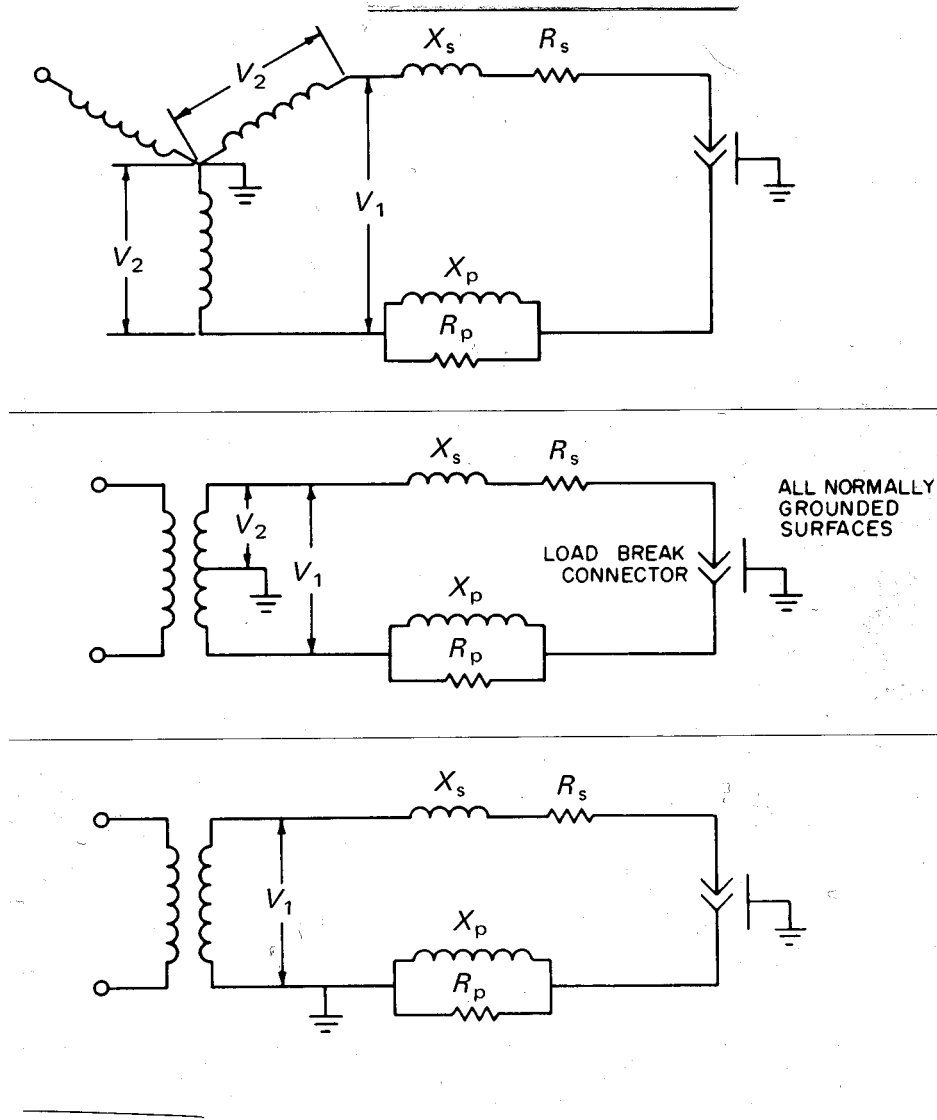

$$\frac{X_s}{R_s} = 5 \text{ to } 7$$

Power factor = 70% to 80% lagging

$$Z_s = 10\% - 14\% \text{ of } \frac{V_1}{200 \text{ A}}$$

$$Z_s = X_s + R_s$$

NOTES

- 1—Care shall be exercised in the selection and connection of instrument transformers to ensure that they will not significantly alter the waveshape, magnitude, or duration of transient voltages or current normally associated with the test circuit.
- 2—The switching rating may be achieved with the separating parts in either position.
- 3—Series impedance, which may include source impedance, may appear on either side of the load-break connector.
- 4—Transformer loading that represents normal service conditions can be used for switching.

Figure 19—Circuit diagrams for switching current tests

Table 6—Voltage conditions for switching test

Connector voltage rating (kV rms) ^a	Figure 19 test voltage		Test circuit diagram required (see figure 19)
	V ₁	V ₂	
8.3	8.3	—	C
8.3/14.4	14.4	8.3	A or B
15.2	15.2	—	C
15.2/26.3	26.3	15.2	A or B
21.1	21.1	—	C
21.1/36.6	36.6	21.1	A or B

^aThe highest steady-state voltage across the open contacts that a load-break connector is rated to switch is the maximum phase-to-ground rms voltage for phase-to-ground rated devices and the maximum phase-to-phase rms voltage for phase-to-ground/phase-to-phase rated devices.

Table 7—Elbow spacing for switching and fault-closure tests

Connector voltage rating (kV rms)	Maximum center-to-center spacing	
	mm	in
8.3	82.6	3-1/4
8.3/14.4	82.6	3-1/4
15.2	101.6	4
15.2/26.3	101.6	4
21.1	139.7	5-1/2
21.1/36.6	139.7	5-1/2

NOTE—Tests shall be conducted with adjacent grounds exposed as in normal service.

7.7.2 Operating procedures for switching test

The load-break connector under test shall be operated with a suitable live-line tool. Successive switching operations shall be performed at a time interval of not less than 1 min. (Manufacturers may test their products under conditions of a reduced time interval.) The operator shall maintain a minimum dwell time of 5 s after the probe is positioned in the arc extinguishing area of its mating part. Time between closing and opening of the test connector shall allow steady-state voltage and current conditions to be achieved prior to opening. The operator shall perform the closing and opening operations with positive continuous motion so as not to tease the contacts.

7.8 Fault-closure test

This test is applicable to load-break connectors only. The purpose of the test is to verify that the connector is capable of closing on the fault current given in table 2.

Fault-closure tests shall be conducted on connectors from the lot that has passed the switching test (7.7). Any connector from this lot that has successfully completed ten switching operations may be used in the fault-closure test and shall be used in the same sequence in both tests. The test conditions shall be as shown in table 8 and figure 20. At least one connector shall be closed at an instant when the voltage is 80% or more of its peak value.

Table 8—Voltage conditions for fault-closure test

Connector voltage rating (kV rms)	Figure 20 test voltage (kV rms)		Test circuit diagram required (see figure 20)
	V ₁	V ₂	
8.3	8.3	—	B
8.3/14.4	14.4	4.2	A
15.2	15.2	—	B
15.2/26.3	26.3	7.6	A
21.1	21.1	—	B
21.1/36.6	36.6	10.6	A

The sample lot will have successfully passed the fault-closure test if ten consecutive samples meet the following criteria:

- a) Oscillograms show no external ground current.
- b) All parts remain within the closed connector assembly.

Connectors need not be operable after this test.

7.8.1 Mounting preparation of load-break connectors for fault-closure test

Mounting preparation of the load-break connector shall be the same as specified in 7.7.1.

7.9 Current-cycling test for uninsulated components of 600 A connectors

The purpose of this test is to demonstrate the ability of the uninsulated components of the connector system to maintain their required continuous current-carrying capability when subjected to cyclical loads.

Tests shall be conducted in accordance with ANSI C119.4-1991. A 750 kcmil aluminum conductor shall be used for 600 A connectors.

The test shall be made without insulation on the conductor or current-carrying parts of the connector to avoid any deterioration of the insulation that may otherwise occur at the maximum temperature of this test.

The conductor system shall meet the requirements given for Class A connectors in ANSI C119.4-1991.

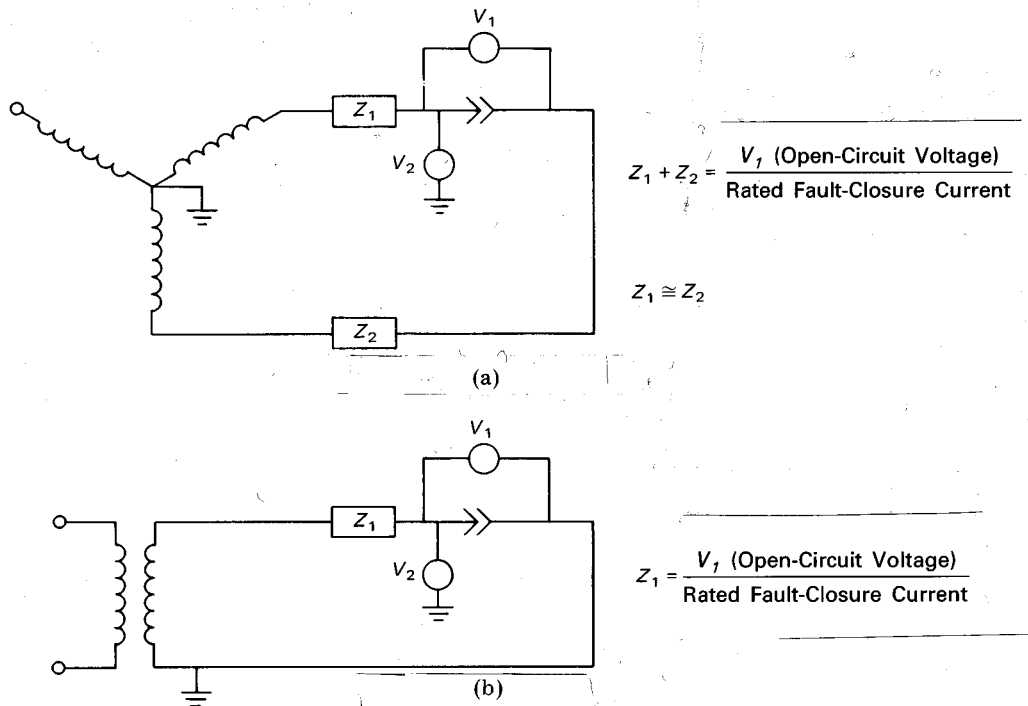

NOTE—Any circuit that duplicates the voltages V_1 and V_2 and the conditions in table 2 is acceptable for conducting the fault-closure test.

V_1 = Required voltage across contacts prior to flow of fault current

V_2 = Required voltage from each contact to all normally grounded surfaces during flow of fault current

Figure 20—Circuit diagrams for fault-closure tests

7.10 Current-cycling test for 200 A insulated connectors

7.10.1 Accelerated thermal test

The purpose of this accelerated test is to demonstrate that 200 A insulated connectors can carry rated current under usual service conditions. Successful completion of the test listed below shall be considered as evidence that the connector meets its rating.

A control cable, used for the purpose of obtaining conductor temperature, shall be installed in the heat cycle loop between two equalizers. Its length shall be 1829 mm (72 in). The control cable shall be the same type and size as the cable used to join the connectors under test.

Four connectors shall be assembled in series on AWG No. 1/0 insulated aluminum conductors having a length of 914 mm (36 in). The cable insulation thickness shall be selected according to its voltage class (see table 9).

Equalizers used shall be in accordance with ANSI C119.4-1991.

Table 9—Cable insulation thickness for accelerated thermal test

Voltage rating (kV rms)	Cable insulation thickness (mil)
15	175
25	260
35	345

The bushing bus shall be a flat, rectangular, bus bar 356 mm (14 in) long, 102 mm (4 in) wide, and 10 mm (3/8 in) thick. The bushing wells shall be mounted with 305 mm (12 in) center-to-center spacing along the center line of the bus bar. The bushing well studs shall be tightened to the bus bar using an installation torque of 9 ± 1 N·m (80 ± 10 lbf·in).

Unless otherwise specified by the manufacturers, the elbow male contact probe shall be threaded into the elbow compression lug using an installation torque of 9 ± 1 N·m (80 ± 10 lbf·in).

Current-cycling tests shall be conducted at an ambient temperature of 15–35 °C in a space free of drafts.

The current-cycle amperes shall be adjusted during the current-on period of the first five cycles to result in a steady-state temperature rise of 100–105 °C on the control conductor. This current shall then be used during the remainder of the test current-on periods, regardless of the temperature of the control conductor.

The test shall consist of 50 current cycles, with the current on 4 h and off 2 h for each cycle. At the end of each current-on cycle the assembly shall be de-energized and within 3 min shall be submerged in water at $5 \text{ °C} \pm 5 \text{ °C}$ for the remainder of the current-off cycle. At the end of the 10th, 25th, and 40th cycles (± 2 cycles), after the samples have returned to room temperature, a short-time ac rms current of 3500 ± 300 A shall be applied to each sample for a minimum of 3 s.

The temperature of at least the following current transfer points shall be measured at the end of each cycle with the current on:

- a) Probe to compression lug
- b) Probe to female contact
- c) Female contact structure to metallic housing
- d) Between bushing insert and bushing well

These temperatures shall not exceed the temperature of the control conductor.

The temperature differences between the control conductor and the connector shall show a condition of stability from the fifth cycle to the end of the test, as indicated by a decrease of this difference of not more than 10 °C from the average of the measured differences in this interval for this connector.

The dc resistance of the connector system shall be measured at the end of cycles 10, 20, 30, 40, and 50 (± 2 cycles). The dc resistance measurements shall be made between the elbow cable equalizer and the bushing stud after the connector system has stabilized at ambient temperature. Ambient temperature shall be measured by devices located within 61 cm (2 ft) of the test loop but in a location that minimizes the effect of thermal convection. The ambient temperature shall be recorded at the same time as each set of resistance measurements, and the resistance shall be corrected to 20 °C. The dc resistance shall be stable over the period

of measurement. Stability is achieved when any resistance measurement, including allowance for instrument accuracy, does not vary by more than $\pm 5\%$ from the average of all the measurements in this interval.

7.10.2 Thermal test with off-axis operation

The purpose of this test is to demonstrate that load-break and dead-break 200 A connectors can carry rated load current after being subjected to an off-axis operating force. Successful completion of these tests shall be considered as evidence that the connector meets its rating.

Each connector shall be subjected to 6 cycles, each consisting of a mechanical operation as specified in 7.10.2.1 and current cycling as specified in 7.10.2.2.

The elbow shall be disassembled with a 12.7 mm (0.5 in) wide pulling band, as shown in figure 21 for application of an off-axis force. Grounding tabs or other obstructions may be removed to apply the pulling band. No provision is made for an off-axis closing force since it is not consistently reproducible.

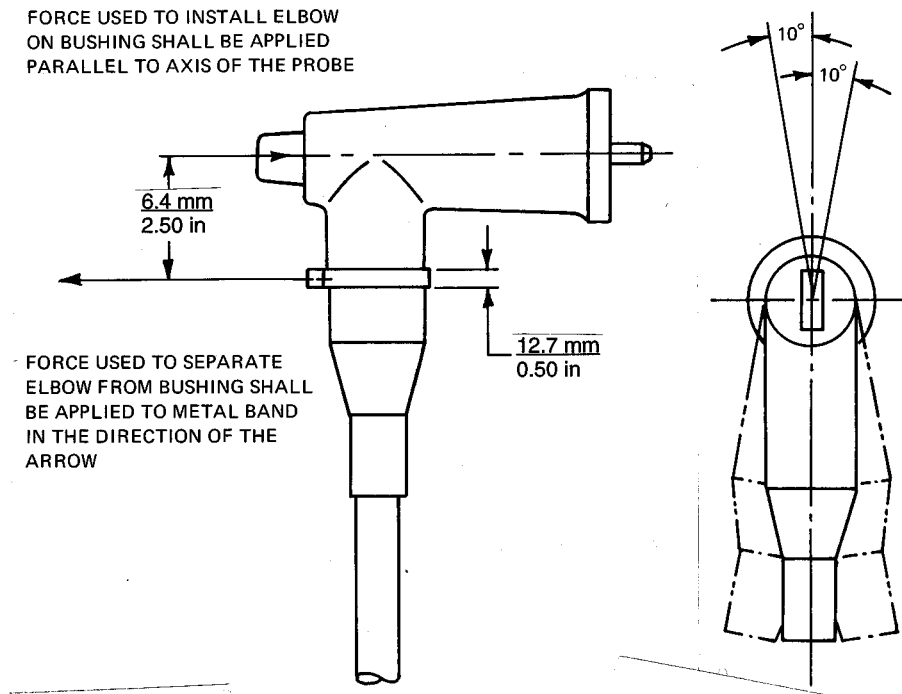

Figure 21—Operating-force test for 7.10.2

Four connectors shall be assembled in series on unsecured AWG No 1/0 cross-linked polyethylene (XLPE) insulated aluminum conductors having a length of 914 mm (36 in). The cable insulation thickness shall be selected according to its voltage class. The applicable voltage class cable that shall be used is given in table 10.

Table 10—Cable insulation thickness for thermal off-axis test

Voltage rating (kV rms)	Cable insulation thickness (mil)
15	175
25	260
35	345

7.10.2.1 Mechanical operation

The elbow shall be rotated about the probe axis a minimum of ten degrees in both the clockwise and counterclockwise directions by means of a suitable live-line tool. The tool shall be approximately parallel with the axis of the probe.

The connector shall then be opened five times with the force applied to the pulling band and closed five times with the force applied to the operating eye. The force required to open or close the elbow shall be parallel to the axis of the probe. The applied force shall be sufficient to completely close the connector.

7.10.2.2 Current cycling test

A control cable, used for the purpose of obtaining conductor temperature, shall be installed in the current-cycling loop between two equalizers. Its length shall be 1829 mm (72 in). The control cable shall be the same type and size as the cable used to join the connectors under test.

The current shall be adjusted so that the temperature on the conductor of the control cable is $90\text{ }^{\circ}\text{C} \pm 5\text{ }^{\circ}\text{C}$. The current shall be applied for eight continuous cycles, each cycle consisting of 3 h on and 3 h off.

Equalizers used shall be in accordance with ANSI C119.4-1991.

Current-cycling tests shall be conducted at an ambient temperature of 15–35 °C in a space free of drafts.

The temperature shall be measured by thermocouples located

- a) At the compression lug
- b) At the approximate midpoint of the bushing contact or as near thereto as practical
- c) On the conductor surface at the midpoint of the control cable

The temperature at locations a) and b) shall not exceed the temperature of the conductor of the cable at location c).

7.11 Current-cycling test for 600 A insulated connectors

The purpose of this test is to demonstrate that 600 A insulated connectors can carry rated current under usual service conditions. Successful completion of the test listed below shall be considered as evidence that the connector meets its rating.

A control cable, used for the purpose of obtaining conductor temperature, shall be installed in the current-cycling loop between two equalizers. Its length shall be 1829 mm (72 in). The control cable shall be the same type as the cable used to join the connectors under test.

Four connectors shall be assembled in series on 750 kcmil insulated aluminum conductors having a length of 914 mm (36 in). The cable insulation thickness shall be selected according to its voltage class (see table 11).

Table 11—Cable insulation thickness for 600 A current cycling test

Voltage rating (kV rms)	Cable insulation thickness (mil)
15	175
25	260
35	345

Equalizers used shall be in accordance with ANSI C119.4-1991.

Current-cycling tests shall be conducted at an ambient temperature of 15–35 °C in a space free of drafts.

The current-cycle amperes shall be adjusted to result in a steady-state temperature of 90 °C ± 5 °C on the surface of the conductor of the control cable. The temperature shall be measured at the approximate center of the control cable.

The test shall consist of 50 current cycles, with the current on for 6 h and off for 6 h for each cycle. The temperature of the hottest spot of the connector shall be measured every 10 cycles and shall not exceed the temperature of the conductor of the control cable.

7.12 Accelerated sealing life test

The purpose of this test is to demonstrate that the connector can maintain a long-term seal at all interfaces to prevent the entrance of moisture.

Four samples shall be assembled on AWG No. 1/0 aluminum conductors for 200 A connectors and 750 kcmil aluminum conductors for 600 A connectors.

The cable shall be compatible with the thermal conditions of this test. A mandrel simulating the test cable may be substituted during the oven aging portion of this test.

The four connector assemblies shall be placed in an oven having 121 °C temperature and remain there for three weeks. After this time has elapsed, the four samples shall be removed from the oven and each operated once by using the operating eye or an appropriate location on the axis of the separable interface.

The four connector assemblies shall then be subjected to 50 cycles of the following sequence of operations:

- a) The assemblies shall be heated in air using sufficient current to raise the temperature of the conductor of the control cable to 90 °C ± 5 °C for the following time period:
 - 200 A connectors—1 h
 - 600 A connectors—4 h
- b) The assemblies shall be de-energized and within 3 min shall be submerged in 25 °C ± 10 °C conductive water (5000 ³/₄ cm maximum) to a depth of 30 cm (1 ft) for the following time periods:

200 A connectors—1 h

600 A connectors—2 h

After the 50th cycle, the connector and cable assembly shall withstand a design impulse test (see 7.5.3).

The test point, if provided, shall be capable of passing the voltage test specified in 7.17.2.

7.13 Cable pull-out test (tensile strength)

The purpose of this test is to determine if the connection between the cable conductor and compression lug of the connector is capable of withstanding a tensile force of 890 N (200 lbf).

The compression lug shall be held in a manner that will not affect the strength of the connection. The tensile force shall be applied to the cable conductor.

The connection shall withstand the applied force for 1 min without impairing the connector's ability to meet the other requirements of this standard.

7.14 Operating-force test

The purpose of this test is to demonstrate that the force necessary to operate a connector meets the requirements of 6.2.

The elbow shall be assembled with a probe and compression lug and the connector system shall be lubricated in accordance with the manufacturer's instructions.

The temperature of the components shall be $-20\text{ }^{\circ}\text{C}$, $+25\text{ }^{\circ}\text{C}$, and $+65\text{ }^{\circ}\text{C}$ respectively, for three separate tests. Each test shall consist of closing the connector and then reopening it within 10 min. The force shall be applied to the operating eye parallel to the axis of the probe at a rate of 127 mm/min (5 in/min).

The forces required to open or close the connector shall be within the ranges specified in 6.2.

7.15 Operating-eye test

The purpose of this test is to demonstrate that the operating eye meets the requirements of 6.2 at $25\text{ }^{\circ}\text{C} \pm 5\text{ }^{\circ}\text{C}$.

A tensile force shall be gradually applied to the operating eye in the direction of normal operation. The operating eye shall withstand the force for 1 min.

A rotational force shall be applied with a suitable live-line tool to the operating eye in a clockwise direction and in a counter-clockwise direction.

Some distortion of the operating eye is acceptable provided that the connector is serviceable after the test and meets the corona voltage-level requirement specified in table 1.

7.16 Test point cap test

The purpose of this test is to demonstrate that the removal force of the test point cap meets the requirements of 6.5.2 and the cap operating eye is capable of withstanding the maximum operating force.

7.16.1 Test point cap operating-force test

A tensile force shall be gradually applied to the test point cap in the direction parallel with the probe axis at $-20\text{ }^{\circ}\text{C}$, $+25\text{ }^{\circ}\text{C}$, and $+65\text{ }^{\circ}\text{C}$.

The force required to remove the test point cap shall be within the ranges specified in 6.5.2.

7.16.2 Test point cap operating withstand test

A tensile force of 445 N (100 lbf) shall be applied to the test point cap operating eye for 1 min at $-20\text{ }^{\circ}\text{C}$, $+25\text{ }^{\circ}\text{C}$, and $+65\text{ }^{\circ}\text{C}$.

Some distortion of the operating eye is acceptable provided that the test point cap is serviceable after the test.

7.17 Test point tests

7.17.1 Test point capacitance test

The purpose of this test is to verify that the capacitance values of the test point meet the requirements of 6.5.1.

The connector shall be installed on a cable of the type for which it is designed to operate, and the shielding shall be grounded in the normal manner. The capacitances from test point to cable and test point to ground shall be measured with suitable instruments and proper shielding techniques.

The measured values shall be within the tolerances specified in 6.5.1.

7.17.2 Test point voltage test

The purpose of this test is to ensure proper operation of the test point.

A test voltage shall be applied to the conductor system of the connector. The response of a suitable sensing device on the test point shall indicate an energized condition.

7.18 Shielding test

The purpose of this test is to demonstrate that the shielding meets the requirements of 6.3.

The test procedure shall be in accordance with IEEE Std 592-1990.